



STD2 Submittal Package

atmosphere is everything

14716 S. BROADWAY, GARDENA, CA 90248 • Ph: (310)532-1555 Fax: (310)-532-3030 • www.marsair.com
© Copyright Mars Air Systems, LLC 2014

STD2 Electric Heated Series 2

Standard Series 2
Commercial Air Curtain
Submittal Package

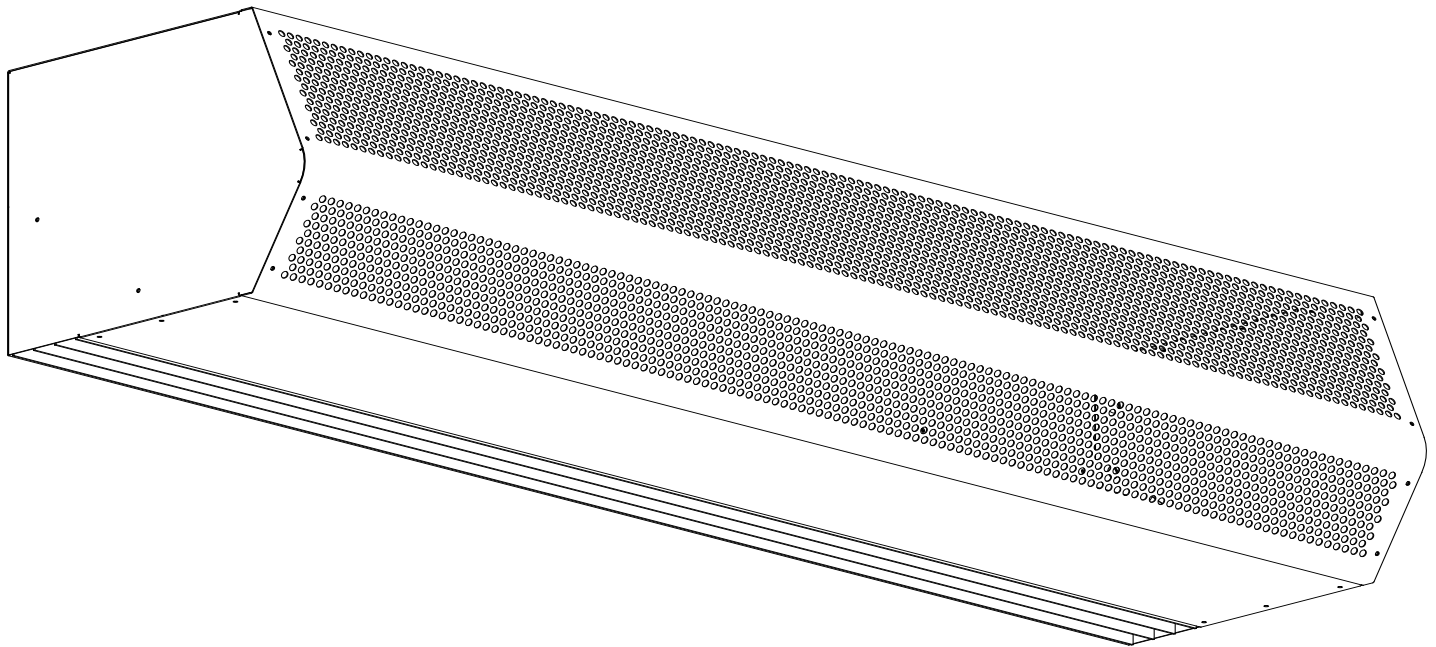

Submitted by:
Mars Air Systems, LLC
14716 S. Broadway
Gardena, CA 90248

P.O.#	
S.Q.	
Company	
Print Name	
Signature	
Date	

(Electronic Signature Preferred)

Company Seal or Stamp

NOTE: MARS AIR SYSTEMS, LLC reserves the right to change specifications and product design without notice. Such revisions do not entitle the buyer to corresponding changes, improvements, additions, or replacements for previously purchased equipment.



Table of Contents

<u>Page #</u>	<u>Content</u>
3-4	STD2 Electric Submittals
5-6	Typical Electric Heated Wiring Diagrams
7	Thermostat Submittals
8-9	Accessory Installation Supplement
10-13	Installation, Operation and Maintenance
14-15	Troubleshooting Guide
16	Warranty
17-18	Heated Products Supplement
19-30	CSI Spec
31	Reference Links



atmosphere is everything

14716 S. Broadway • Gardena, CA 90248 • USA
 TEL: (310) 532-1555 • (800) 421-1266 • FAX: (310) 324-3030
 Web Site: www.marsair.com • E-mail: info@marsair.com

PROJECT		OPTIONS/ITEMS	
TITLE			
COMMENTS		DATE 4/14/15	PAGE
		REV. NO	
MODEL NO. STD2 Series	DRAWING NO STD2ELC-F	DRAWN BY NT	CHECKED BY
		FILE NAME	

Electric Heated Drawing

STD2 (Standard 2 Series)

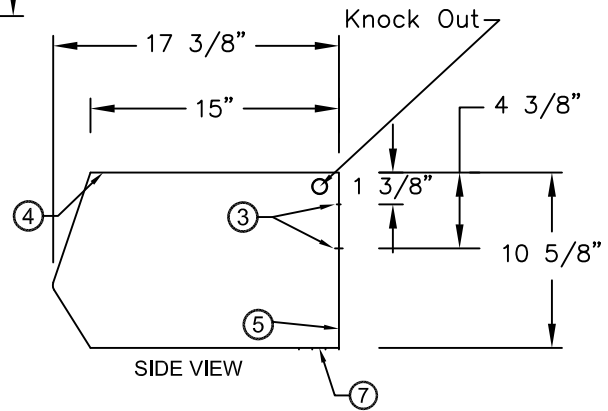
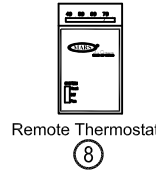
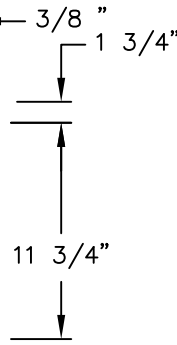
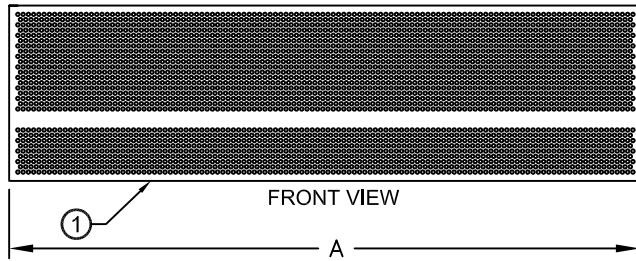
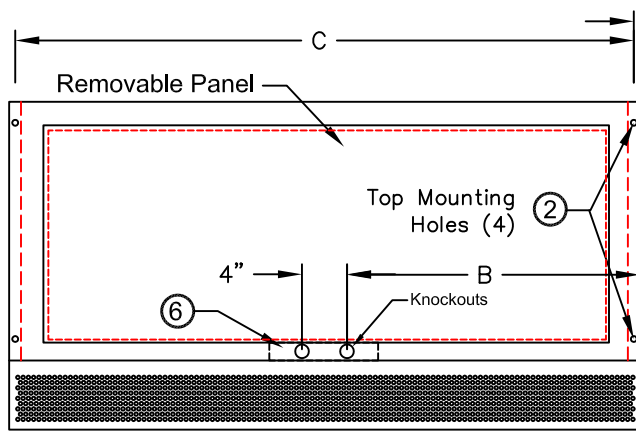

10 Recommended Accessories

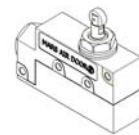

*- Use corresponding letters in "Voltage Code" then "Wattage Code" columns to complete the model numbers.

Note: MARS reserves the right to change specifications and product design without notice. Such revisions do not entitle the buyer to corresponding changes, improvements additions or replacements for previously purchased equipment.

Model Number	OVERALL LENGTH A (in)	KNOCKOUT LOCATION B (in)	REAR MOUNTING CENTER C (in)
STD236-1E**-OB	36	16	35 1/4
STD242-1E**-OB	42	19	41 1/4
STD248-1E**-OB	48	22	47 1/4
STD260-2E**-OB	60	13	59 1/4
STD272-2E**-OB	72	16	71 1/4
STD284-2E**-OB	84	19	83 1/4
STD296-2E**-OB	96	22	95 1/4
STD2108-3E**-OB	108	52	107 1/4
STD2120-3E**-OB	120	58	119 1/4
STD2144-3E**-OB	144	70	143 1/4

Notes:

- This product is designed to meet the National Electric Code (NEC) and is ETL listed for the US and Canada (UL 2021 and CSA 22.2).
- (4) 7/16" mounting holes provided on for overhead mounting provided, (2) on each end.
- (2) 1/2" key hole slots and (2) 7/16" mounting holes are provided on each end of the back side for wall mounting.
- All units have a self contained one piece cabinet, fire retardant and corrosion proof paint lock metal double protected with baked on Obsidian Black color, rust preventative electrostatic polyurethane powder coating.
- Cabinet is to be mounted from overhead or fastened to a wall and has sufficient strength for suspension from both ends without intermediate support.
- Control panel is pre-wired and pre-mounted inside the cabinet.
- Unit is to be installed such that air flow is unobstructed. Unit has a 3" air discharge nozzle containing adjustable air directional vanes with 40° sweep front to back.
- Wall mounted 24 volt thermostat with remote "heat/off/fan" switch is shipped loose and field installed. Terminal block provided inside control panel.
- Circuit protection as per NEC by others.
- Door limit switch and mounting brackets are field installed and/or wired by others. The door limit switch is to be mounted such that the air curtain turns on as door begins to open. To prevent unit damage, the mounting brackets must be installed such that the bottom of the air curtain is not below the door header.

STD2 (Standard 2) Series

Electric Heated

Model Lengths 36" – 144"



atmosphere is everything

14716 S. BROADWAY, GARDENA, CA 90248 • Ph: (310)532-1555 Fax: (310)-532-3030 • www.marsair.com
© Copyright Mars Air Systems, LLC 2014

Electric Heated Data Sheet

Applications: Environmental Separation: Max Height 12' / Insect Control: Max Height 10'

STD2 (Standard) Series 2 Model Number	Mechanical Data						Lab Data				
	Nozzle Length (in)	Length (in)	Depth (in)	Height (in)	Motor (hp)	Weight (lbs)	Max Core Velocity at Nozzle (fpm)	Avg Velocity (fpm)	Volume (cfm)	Uniformity (%)	Power Rating (watts)
STD236-1E**-OB	36	36	17.5	11	1/2	90	5960	2206	1379	84	500
STD242-1E**-OB	42	42	17.5	11	1/2	95	4865	1945	1418	87	510
STD248-1E**-OB	48	48	17.5	11	1/2	100	4247	1730	1442	85	550
STD260-2E**-OB	60	60	17.5	11	Two 1/2	130	6737	2592	2700	93	940
STD272-2E**-OB	72	72	17.5	11	Two 1/2	180	5960	2206	2758	84	1000
STD284-2E**-OB	84	84	17.5	11	Two 1/2	190	4865	1945	2836	87	1020
STD296-2E**-OB	96	96	17.5	11	Two 1/2	225	4247	1730	2884	85	1100
STD2108-3E**-OB	108	108	17.5	11	Three 1/2	270	5960	2206	4137	84	1500
STD2120-3E**-OB	120	120	17.5	11	Three 1/2	280	4660	2084	4341	92	1570
STD2144-3E**-OB	144	144	17.5	11	Three 1/2	330	4247	1730	4326	85	1650

* - Use corresponding letters in "Voltage Code" & Wattage Code" to complete the model numbers.

Note: Data above for 1725 RPM at 60 Hz, 50 Hz is 1425 RPM with a 17% reduction in the performance data.

Features:

- Air Curtain
 - 1/2 HP Continuous Duty TEAO Motors
 - Sleek self-contained one-piece heavy gauge corrosion proof paint lock metal design
 - ETL Certified to conform to UL 2021 (US) and CSA 22.2 (Canada) Standards
 - (4) 7/16" top and wall mounting holes provided
 - Cabinet has sufficient strength for fastening to wall on both ends without intermediate support
 - Adjustable air directional vanes with 40° sweep front to back
 - Standard color is Obsidian Black
 - Rust preventative electrostatic polyurethane powder coating
 - 18-month parts warranty
 - Freight Included (FOB Continental USA)
 - Proudly Made in the USA
- Electric Heater Coil and Wiring
 - Coils are an open type for rapid temperature rise to be located in the air curtain's intake directly in the air stream
 - Manual reset thermal overload protection provided
 - Controls internally mounted, prewired ready for power connection and accessible through the intake or top access panels
 - 3/4" knockouts are provided on the top and ends
 - An on/off switch is unit mounted at the bottom and the control voltage is 24 volts
 - A wall mounted 24-volt thermostat is included (field wired and installed by others)

Three Phase Electrical Data (FLA)	Unit Voltage (Voltage Code) Amperage				Heater kilowatts (Wattage Code) kW			Temp Rise °F
	208v/3Ø (E)	230v/3Ø (F)	460v/3Ø (H)	575v/3Ø (I)	(H)	(N)	(S)	
	STD236-1E**-OB	36.0	33.0	16.0	13.0	12	-	-
STD242-1E**-OB	36.0	33.0	16.0	13.0	12	-	-	27
STD248-1E**-OB	36.0	33.0	16.0	13.0	12	-	-	26
STD260-2E**-OB	72.0	66.0	32.0	26.0	-	24	-	28
STD272-2E**-OB	72.0	66.0	32.0	26.0	-	24	-	27
STD284-2E**-OB	72.0	66.0	32.0	26.0	-	24	-	27
STD296-2E**-OB	72.0	66.0	32.0	26.0	-	24	-	26
STD2108-3E**-OB	108.0	98.0	48.0	39.0	-	-	36	27
STD2120-3E**-OB	108.0	98.0	48.0	39.0	-	-	36	26
STD2144-3E**-OB	108.0	98.0	48.0	39.0	-	-	36	26

* - Use corresponding letters in "Voltage Code and Wattage Code" to complete the model numbers.

For Ampacity Multiply FLAX 1.25

Motor amps per motor: 5.1A @ 115v; 2.5A @ 208/230v/1Ø; 1.8A @ 208v/3Ø; 1.6A @ 230v/3Ø; 0.8A @ 460v/3Ø; 0.7A @ 575v/3Ø.

Mars Recommended Accessories (See Submittals for additional details):

- Door Limit Switches
 - 99-014, Combination mechanical switch, 250V, 1HP Max
 - 99-018, Commercial surface mounted magnetic switch, 24V
- Controllers
 - SK-EU, SimpleLink, 208V-575V, (460-575V, 3PH needs additional 115-230V, 1PH power), Integral Control, Nema1
- Factory Mounted Options
 - INS-TD, Adjustable time delay (1 sec to 17 min)
 - INS-HD, Heat on demand
 - BMS-300, BMS for monitor and control
 - Note: Dry contact provided in panel for monitoring motor and heater. 24Vac signal provided from panel for controlling motor and heater.
- Disconnects
 - 99-122 & 99-123, Non-Fused Disconnect, remote mounted, 600V, 32A & 80A respectively, 3 Pole, IP65
 - 99-***, Fused Disconnect, remote mounted, 240V-600V, 30A-100A, 3 Pole, Nema3R (See disconnect submittals for complete part numbers)
- Brackets
 - B0004, Adjustable mounting bracket set, 3 1/2" clearance
 - B0041, Transom mounting bracket set for STD2
 - 09-510, Vertical mounting kit (Not applicable for units with 16kW/motor, 208V & 230V, 3PH)
- Filters
 - J21**-t, 1/2" aluminum pressed frame bank filters (** = Model Length, t = # of Motors) (Not applicable for units SimpleLink & 16kW/motor, 208V & 230V, 3PH)

Sound Levels: (measured at 10' in an open field)

1 Motor Unit = 66 dBA, 2 Motor Unit = 68 dBA, 3 Motor Unit = 71 dBA & 4 Motor Unit = 73 dBA

Single Phase Electrical Data (FLA)	Unit Voltage (Voltage Code) Amperage		Heater kilowatts (Wattage Code) kW			Temp Rise °F
	208v/1Ø (B)	230v/1Ø (C)	(B)	(H)	(K)	
	STD236-1E**-OB	32.0	29.0	6	-	-
STD242-1E**-OB	32.0	29.0	6	-	-	13
STD248-1E**-OB	32.0	29.0	6	-	-	13
STD260-2E**-OB	63.0	58.0	-	12	-	14
STD272-2E**-OB	63.0	58.0	-	12	-	14
STD284-2E**-OB	63.0	58.0	-	12	-	13
STD296-2E**-OB	63.0	58.0	-	12	-	13
STD2108-3E**-OB	95.0	86.0	-	-	18	14
STD2120-3E**-OB	95.0	86.0	-	-	18	13
STD2144-3E**-OB	95.0	86.0	-	-	18	13

* - Use corresponding letters in "Voltage Code and Wattage Code" to complete the model numbers.

For Ampacity Multiply FLAX 1.25

Motor amps per motor: 2.5A @ 208/230v/1Ø

EXAMPLE

STD2 72 -2 E H N -OB

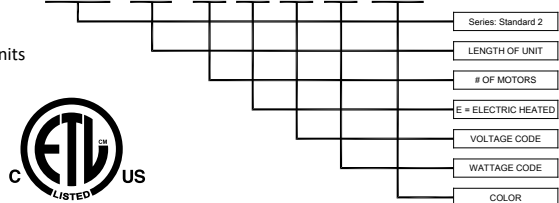

NOTE: MARS AIR SYSTEMS, LLC reserves the right to change specifications and product design without notice. Such revisions do not entitle the buyer to corresponding changes, improvements, additions, or replacements for previously purchased equipment.



atmosphere is everything

14716 S. Broadway • Gardena, CA 90248 • USA
TEL: (310) 532-1555 • (800) 421-1266 • FAX: (310) 324-3030
Web Site: www.marsair.com • E-mail: info@marsair.com

PROJECT		OPTIONS/ITEMS	
TITLE			
COMMENTS		DATE 07/09/19	PAGE
		REV. NO	2
MODEL NO. STD2, PH10, HV2, PH12, EP2	DRAWING NO ST0001	DRAWN BY VM	CHECKED BY FC
		FILE NAME	

Model #: STD2, PH10, HV2, PH12, EP2 36, 42, 48 Heated Air Curtains
208/240Vac, Single Phase, 6kW, 9kW, 9.5kW.

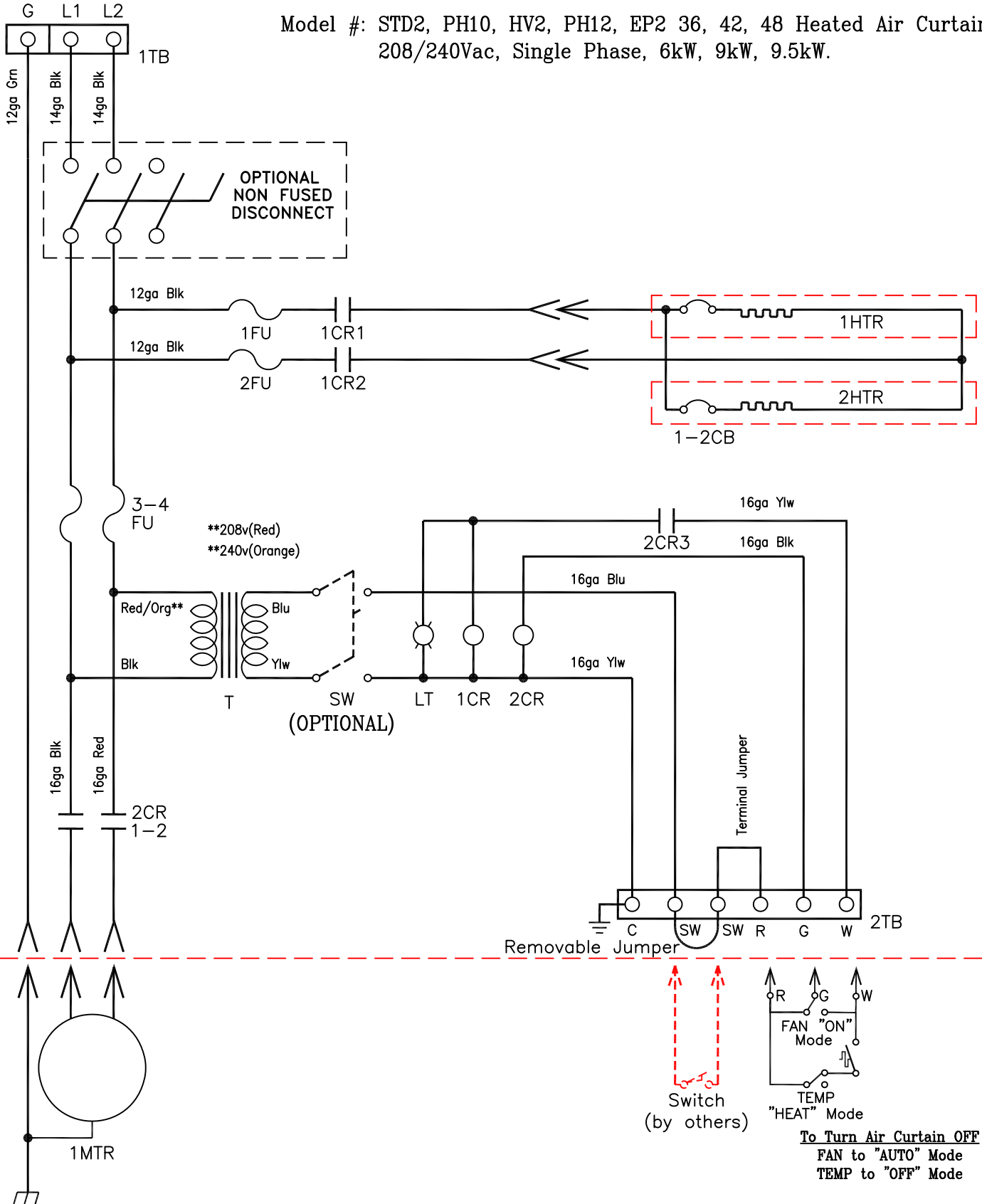



atmosphere is everything

14716 S. Broadway • Gardena, CA 90248 • USA
TEL:(310) 532-1555 • (800) 421-1266 • FAX:(310) 324-3030
Web Site: www.marsair.com • E-mail: info@marsair.com

PROJECT		OPTIONS/ITEMS	
TITLE			
COMMENTS		DATE 11/25/14	PAGE
		REV. NO	1
MODEL NO. STD2, PH10	DRAWING NO ST0636	DRAWN BY NT	CHECKED BY FRC
		FILE NAME	

Model #: STD2 (PH10) 36, 42, 48, 60 Heated Air Curtains
208/240Vac, 1 Phase Motor and 3 Phase Heater, 8kW, 9.5kW, 12kW, 16kW.

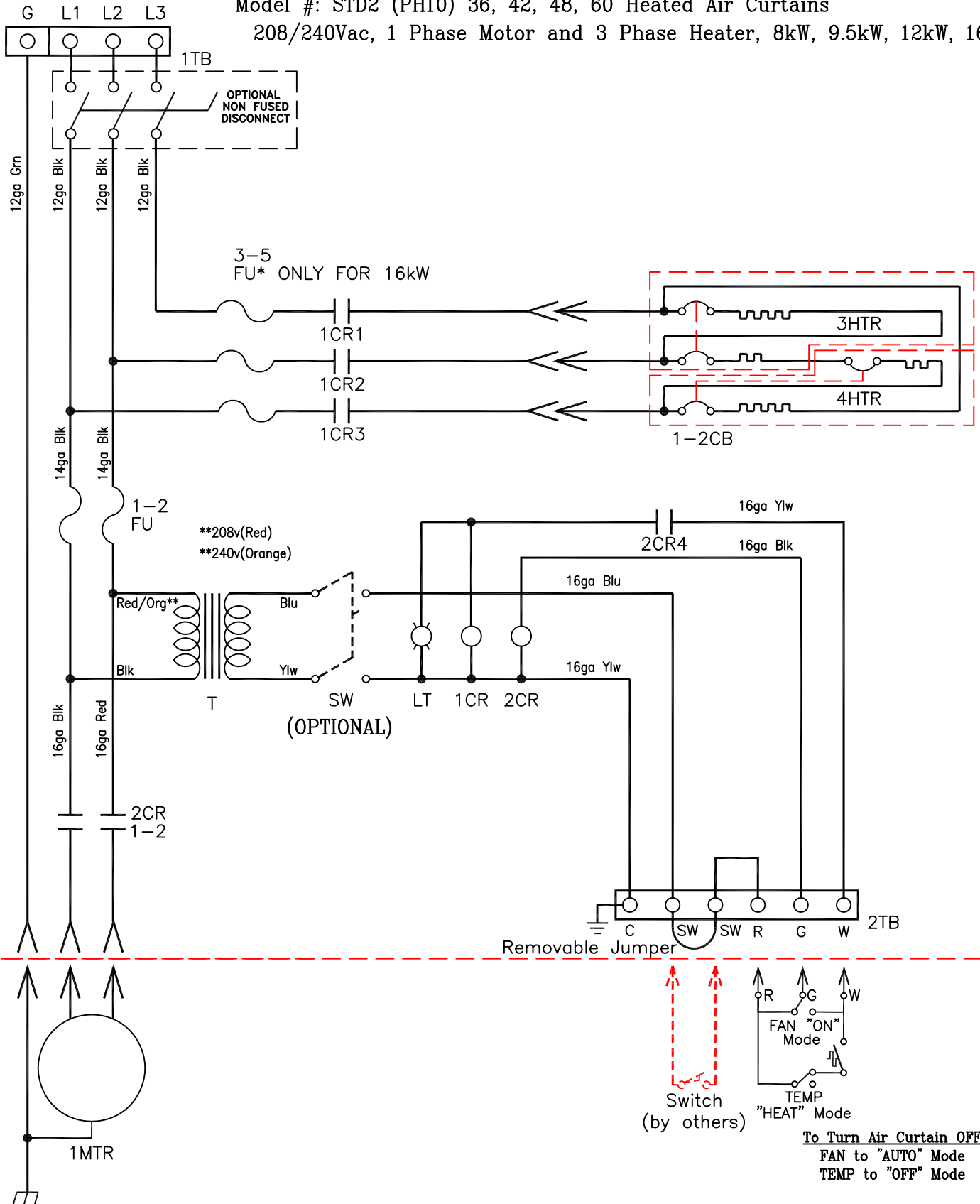

Thermostats



Line voltage to low voltage Models

atmosphere is everything

14716 S. BROADWAY, GARDENA, CA 90248 • Ph: (310)532-1555 Fax: (310)-532-3030 • www.marsair.com
© Copyright Mars Air Systems, LLC 2014

Thermostats

Thermostat Part #	Description	Applicable Air Curtain Series
99-063	Thermostat, 801, Line Voltage, Up to 250V, Analog, Single Stage, Single Pole	LPV2, WM/BD Electric & All Hot Water / Steam
99-064	Thermostat, 802, Line Voltage, Up to 250V, Analog, Two Stage, Double Pole	LPV2 Electric & All Hot Water / Steam
99-264	Thermostat, 9200H, 24 Volt, Analog, Single Pole, R.G.W.Y.B.O.	Elec STD2, HV2, EP2, PH & All Gas Fired
99-277	Thermostat, IC20-101, 24 Volt, Analog, Single Pole, R.W.	LPV2 Electric (Low Voltage Control option)
99-263	Thermostat, RS4110, 24 Volt, Digital, Single Pole, R.G.W.Y.B.O., Battery Power	Elec STD2, HV2, EP2, PH, WM/BD & All Gas Fired

Features:

- ❖ Allows automatic control of heated air
- ❖ Remote mounted (field installed by others)
- ❖ Temperature range from 50F to 90F
- ❖ Regulates the heat near the air curtain
- ❖ Analog Bimetal Temperature Sensing
- ❖ Thermostats are UR (UL Recognized)
- ❖ 1 year warranty

Line Voltage (99-063, 99-064)

- ❖ Standard for LPV2 Electric and All Hot Water/Steam Heated models
- ❖ Single Phase, Single Pole, 250V max
- ❖ Remote Wall Mounted by others
- ❖ Requires Junction Box (J-Box field supplied and installed)

Low voltage (99-264, 99-277, 99-263)

- ❖ Standard for STD2, HV2, EP2, PH, WM/BD Electric and all Gas Heated models
 - ❖ Low voltage (24V) control
 - ❖ Fan and Heat Control Switch
 - ❖ Remote Wall Mounted by others
- *Do not mount low voltage thermostat greater than 30ft from the air curtain. Mounting the low voltage thermostat too far from the air curtain may cause a voltage drop and cause chattering.

Options and Accessories:

- ❖ 2 Stage Line Voltage Thermostat
- ❖ Digital Programmable Low Voltage Thermostat
- ❖ Digital Low Voltage Thermostat with Battery Backup
- ❖ Factory Wired and Installed Thermostat
- ❖ Lockable clear cover

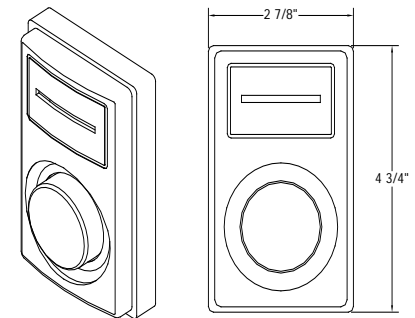

99-063 – Thermostat, 801, Line Voltage, Single Stage, Single Pole

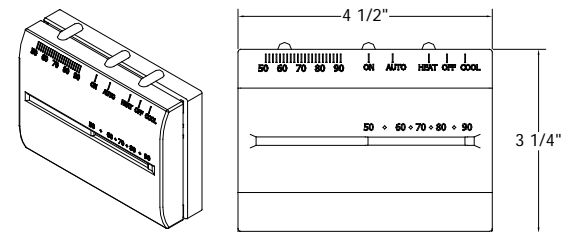

99-264 – Thermostat, 24 Volt, Analog, Single Stage, R.G.W.Y.B.O.

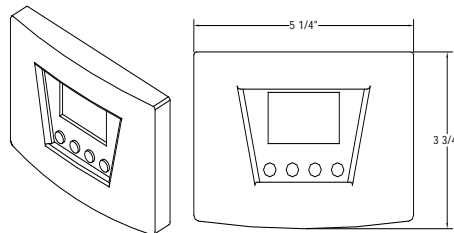

99-263 – Thermostat, 24 Volt, Digital, Single Stage., R.G.W.Y.B.O., Battery Power

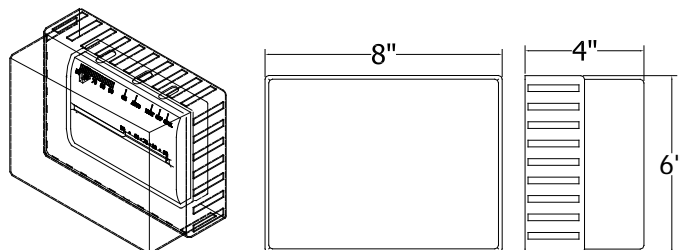

99-182 - Cover, Lockable, Clear

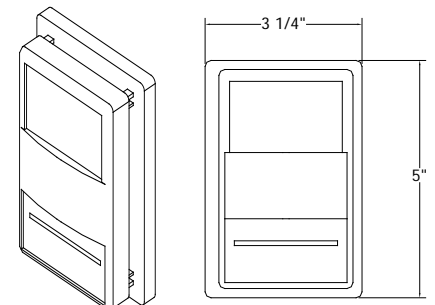

99-277 – Thermostat, 24 Volt, Single Stage, R.W.

NOTE: MARS AIR SYSTEMS, LLC reserves the right to change specifications and product design without notice. Such revisions do not entitle the buyer to corresponding changes, improvements, additions, or replacements for previously purchased equipment.

ACCESSORY INSTALLATION SUPPLEMENT

Door Limit and Magnetic Reed Switches

1. Mars door limit and magnetic reed switches are available with NEMA 1, 4X and 7 ratings. Contact the factory for additional ratings and details. (See FIG. 1 for typical single swing, hinged door type, door limit switch installation)

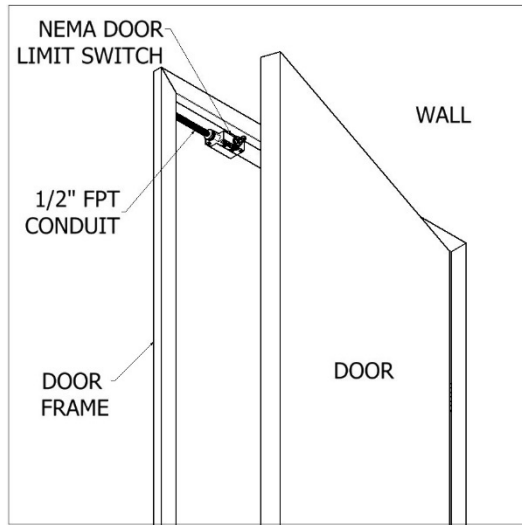

FIG. 1

2. Use light gauge materials when field fabricating brackets to activate and deactivate the door limit switch(s). (FIG. 2) Figure 2 also shows the typical installation of the combination plunger/roller type NEMA 1 door limit switch, for all non-hinged style doors.

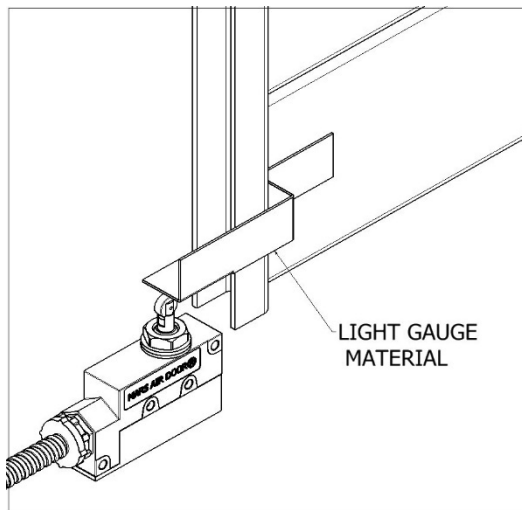

FIG. 2

3. All wiring must be per local and NEC (National Electric Code) codes.
4. Panels or controllers may be required. Refer to wiring diagram inside the control panel box.

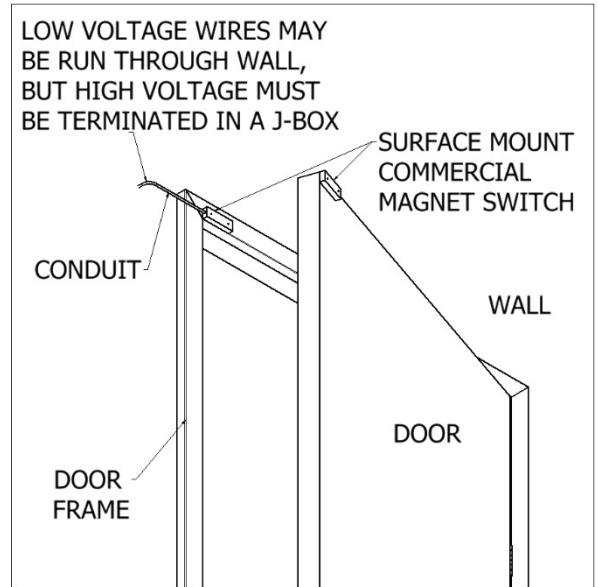

FIG. 3

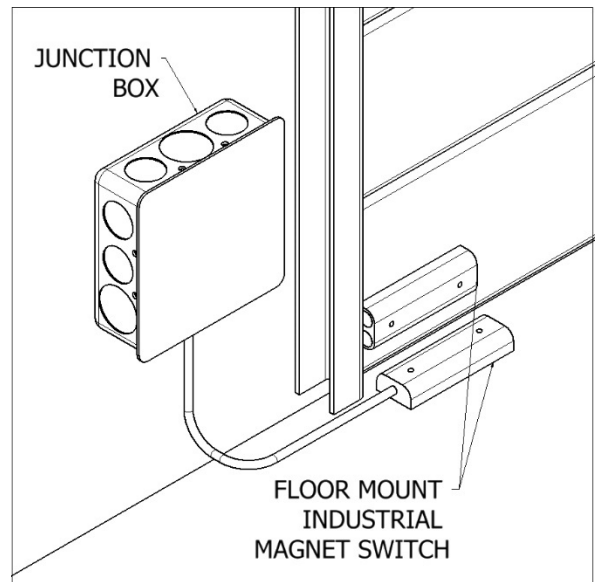

FIG. 4

atmosphere is everything

Bracket Installation

1. Side Extension Plates: For doorways wider than the air curtain, use combination of Side Extension Plates and Adjustable Mounting Brackets. (FIG. 5)

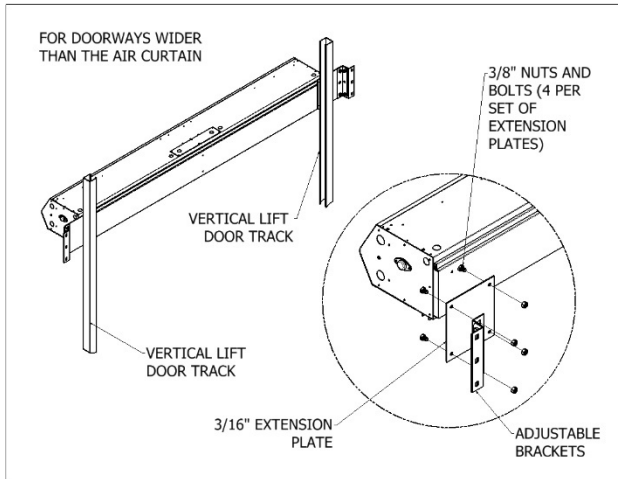

FIG. 5 (LPV SHOWN)

2. Adjustable Mounting Brackets: For installation of air curtain over drum-style roll-up door, use Extended Wall Mounting Brackets. (FIG. 6)

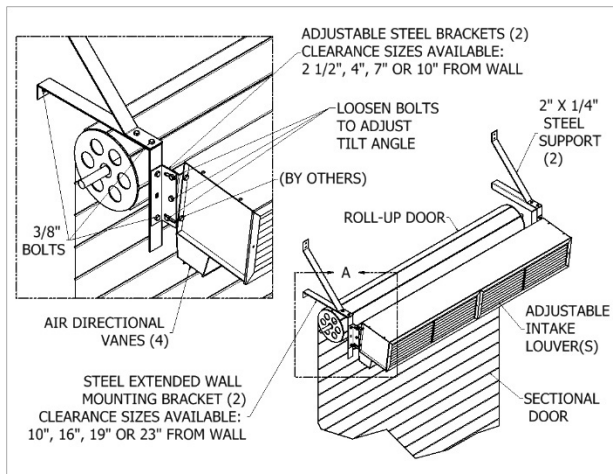

FIG. 6 (STD SHOWN)

3. Extended Wall Mounting: For Tandem Mounting of air curtain over sectional style door, use either wall mounting angle brackets or threaded rods.

4. Top Mounting Brackets: For overhead installation of units, use in conjunction with the threaded holes provided on top of unit.

Note: Angle brackets, threaded rods and I Beams are provided by others. (FIGS. 7 & 8) All optional brackets are not available for WMI/WMH and BD Series.

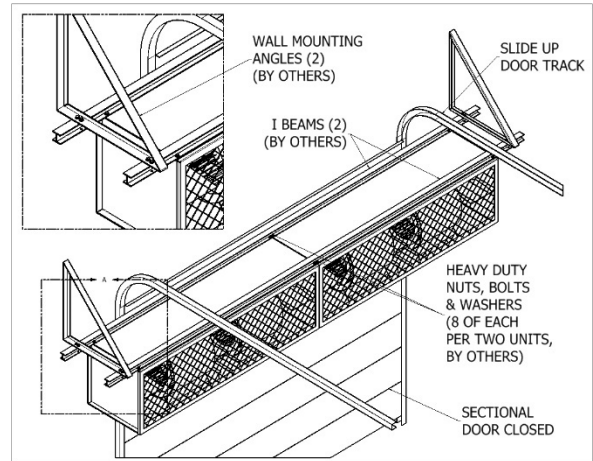

FIG. 7 (WMI/WMH SHOWN)

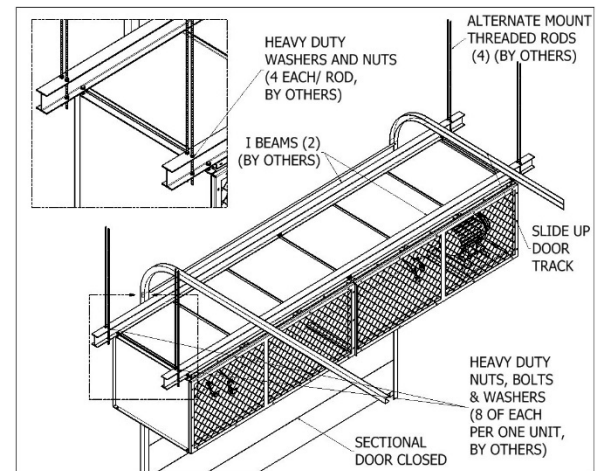

FIG. 8 (BD SHOWN)

STANDARD 2 (STD2), HIGH VELOCITY 2 (HV2), EXTRA POWER 2 (EP2) AND ETL SANITATION CERTIFIED INDUSTRIAL SERIES

Installation, Operation and Maintenance Manual

Please read and save these instructions. Read carefully before attempting to assemble, install, operate, or maintain the product described. Protect yourself and others by observing all safety information. Failure to comply with these instructions could result in personal injury and/or property damage. Retain these instructions for future reference.

OVERVIEW

Mars Air Curtains are designed to cover door openings, providing both temperature control/environmental separation and flying insect control, when the building's doors are opened. Typical installation heights are:

Standard 2 Series (Environmental Separation up to 12', Flying Insect Control up to 10'), High Velocity 2 Series (Environmental Separation up to 14', Flying Insect Control up to 12'), and Extra Power 2 Series (Environmental up to 16', Flying Insect Control up to 14'). All ETL Sanitation Certified Series should be mounted at 7' for Flying Insect Control. The units are typically wall mounted horizontally above the door opening. They can also be suspended from the ceiling or vertically mounted alongside the opening. The units are ETL Listed for either an inside or outside mount. Heated units must be mounted on the inside or the protected side of the opening. The motors used in the Standard 2, High Velocity 2 and Extra Power 2 Series are 1/2HP, 1HP and 3HP, respectively. The ETL Sanitation Series utilizes 1/2HP and 1HP motors.

The Standard 2, High Velocity 2 and Extra Power 2 Series come standard with an air intake grille. They can also be configured with an aluminum mesh air intake filter instead of the air intake grille or in conjunction with it.

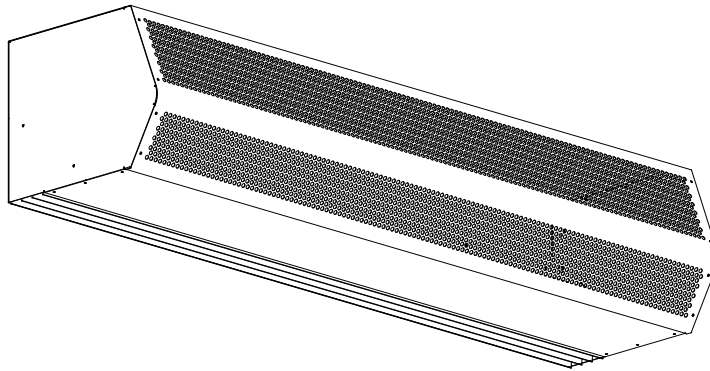

GENERAL SAFETY INFORMATION

Use this product only in the manner intended by the manufacturer. If you have any questions, contact the manufacturer. Only qualified personnel should install this product. Installing personnel should have a clear understanding of these instructions and should be

aware of general safety precautions. Improper installation can result in electric shock, possible injury due to coming in contact with moving parts, as well as other potential hazards.



WARNING

To reduce the risk of fire, electric shock, or injury to persons, observe the following.

- A. Always disconnect, lock and tag power source before installing or servicing product.
- B. Installation work or electrical wiring must be done by qualified person(s) in accordance with all applicable codes and standards, including fire-rated construction.
- C. The combustion airflow needed for safe operation of fuel burning equipment in the area may be affected by the product's operation. Follow the heating equipment manufacturer's guideline and safety standards, such as those published by the National Fire Protection Agency (NFPA), the American Society of Heating, Refrigeration and Air Conditioning Engineers (ASHRAE) and local code authorities.
- D. When cutting or drilling into a wall or ceiling, be careful not to damage electrical wiring and other hidden utilities.



WARNING

When servicing the product, motor may be hot enough to cause pain or injury. Allow motor to cool before servicing.



WARNING

Precaution should be taken in explosive atmospheres.

RECEIVING AND INSPECTION

Upon receiving the product, check to make sure all items are accounted for by referencing the Bill of Lading to ensure all items were received. Inspect each carton for shipping damage before accepting delivery. Notify the freight carrier if any damage is noticed. The carrier will make notification on the delivery receipt acknowledging any damage to the product. All damage should be noted on all copies of the Bill of Lading which is countersigned by the delivering carrier. A Carrier Inspection Report should be filled out by the carrier upon arrival and a report given to the Traffic Department. If damaged upon arrival, file a claim immediately with the carrier. Any physical damage to the unit after acceptance is not the responsibility of Mars Air Systems.

UNPACKING

Verify that all parts, components and accessories, and the correct quantities of each have been received. If any items are missing, report shortages to Mars Air Systems directly to arrange for obtaining the missing items. Again, verify quantities received against those on the Bill of Lading only, as multiple shipments may be involved.

INSTALLATION

Typical Mounting – Wall or Ceiling Mounted Horizontally Above the Door Opening

1. Remove the air intake grille(s) and/or filter(s) from the product and set aside. Only products 48" or less, except HV2 and EP2 models, are shipped with the motor fan assembly (MFA) mounted inside.
2. Measure the housing and center it over the opening. The air curtain shall be equal to or greater than the width of the opening.
3. Total of two (2) key-hole slots and six (6) pre-punched mounting holes are provided for your convenience. The 7/16" pre-punched holes (4) provided, (2) on each end for top/ceiling mounts. The 1/2" key-hole slot and 7/16" pre-punched hole (2) provided, (2) on each end for wall mounts. These holes must be utilized to secure the product to the wall or ceiling. If necessary, holes may be drilled inside the product to align with the stud spacing. All hardware is field provided by others.
4. Mount the product such that the discharge is 1" above the opening and all obstacles. (FIG. 1)

Note: If the product is installed higher than the recommended 1" above the opening, then it must be moved 3/8" away from the wall for every 1" that it is

moved up. Any void between the wall and the product must be sealed, by others, to optimize performance.

5. Use four (4) threaded rods for overhead installation or four (4) threaded bolts for wall installation. All hardware is field provided by others. (FIG. 1)
6. If applicable, optional Adjustable Mounting Brackets, Side Extension Plates and Extended Wall Mounted Brackets are also available for installations over a Vertical Lift or Drum Roll-up type door. (Reference **Accessory Installation Supplement**)
7. If applicable, for tandem installation or products mounted side by side, allow no more than 6" between the two products. For overhead installation using threaded rods, the products may require a beam, by others, to span the full distance of the mounting length. (Reference **Accessory Installation Supplement**)
8. All wires must be connected internal of the unit and some knockouts are provided. However, it may be necessary to create your own knockout, as required.
9. The unit must be wired per NEC and local codes.

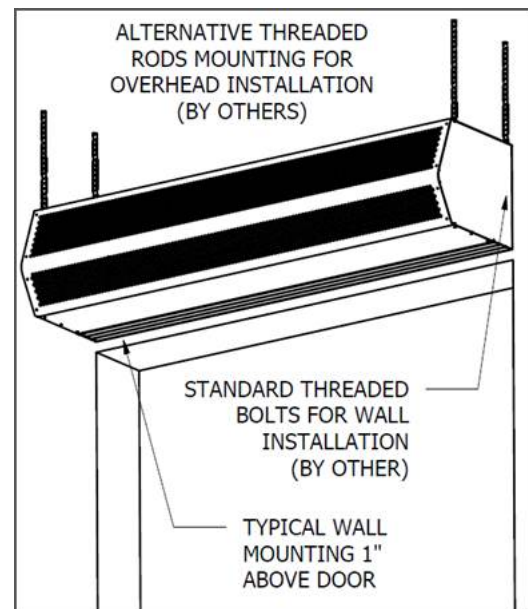

FIG. 1

Motor Fan Assembly Installation and Electrical Field Wiring

1. Once the housing is installed over the opening, the Motor Fan Assembly (MFA) must be re-placed and securely fastened. For products with the MFA shipped loose, wing nuts or hex nuts are provided inside the unit (FIG. 2). For heated MFA installation, reference **Heated Products Supplement Sheet**.
2. The unit and any optional accessories must be wired with the proper voltage to the junction box per the wiring diagram. (FIG. 3, unheated products only)
3. All 3 phase motors are bi-directional, which means they can rotate in either direction. Follow directional arrows on the blower wheel housings for proper rotation. If the motor is rotating incorrectly, switch two of the 3 phase

power or motor leads and the motor will rotate the opposite direction. Make sure all motors are turning in the same and proper direction. (FIG. 2)

4. Replace the air intake grille(s) or filter(s) once the product has been properly tested.

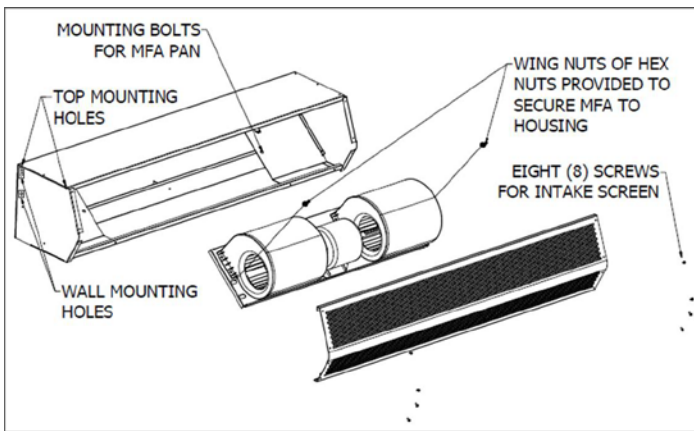
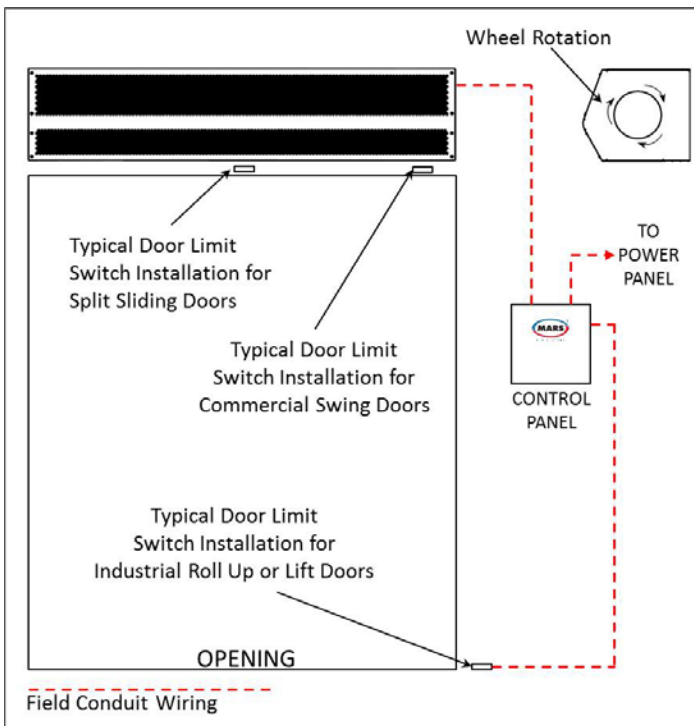

FIG. 2



NOTE

For accessory installation, reference Accessory Installation Supplement.
For heated products, reference Heated Products Supplement.

FIG. 3

START-UP

This product has been assembled and tested at the factory prior to shipping. The following procedures should be performed to assure its performance. Before continuing with the start-up, it is important to recognize the safety controls furnished with the unit.



WARNING

The following items must all be completed by a qualified installer and checked off when completed

- A. Re-check that the product has been installed properly and is level and secure.
- B. Check all terminal screws are tight and field wiring is connected in accordance to National Electrical Code and wired per the enclosed wiring diagram. For electric heated models, ensure that the coils are secured and not touching each other on any metal surface.
- C. Verify proper voltage prior to powering the product. (See product label for reference).
- D. Check all field wired components "if supplied" are wired correctly.
- E. Check that the inlet air supply and the discharge air supply are free of obstructions.
- F. Check that all air filter(s) and/or air intake grille(s) are in place and installed properly, as originally shipped.
- G. Verify voltage to the product once more and turn power on.
- H. Regardless of whether the product is mounted on the inside or outside of the door opening, set the air directional vanes in the discharge nozzle slightly outward to approximately 10-15° towards the outside, or the wind load. (FIG. 4)

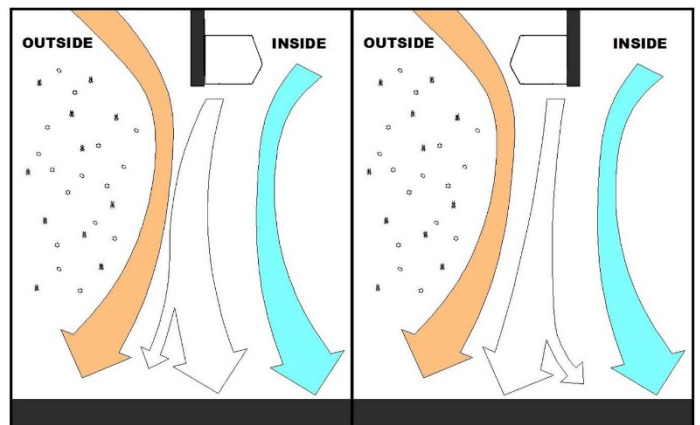

FIG. 4

- I. For products with control panels, turn the HOA (Hand-On-Auto) selector switch to "On" position and open the door to energize the product. For products without

a control panel or an On/Off switch, open the door to energize the product.

- J. If heated products are installed, reference **Heated Products Supplement**.
- K. For three phase units, verify direction of rotation of blower wheels (note direction arrows on the blower wheel housing). Correct if needed by changing polarity of three phase power.
- L. **VERY IMPORTANT** Using a clamp meter, measure the amperage to each motor and ensure that they do not exceed the amperage listed on the product label.
- M. If applicable, adjust the air intake grille(s) such that the output air stream reaches the floor. For temperature control and environmental separation applications, the air stream should reach the floor with sufficient strength to create an air seal around the door opening without creating turbulent mixing of the inside and outside air. For flying insect control applications, the air stream should reach the floor with maximum strength. If after proper installation and adjustment, the product appears to be producing too little or too much air for the application, contact the manufacturer.



WARNING

Prevent hazard of electrical shock. More than one disconnect switch may be required to de-energize this product.

MAINTENANCE



WARNING

To reduce the risk of fire, electrical shock, or injury to persons, observe the following:

- A. Maintenance is to be performed only by qualified personnel who are familiar with local codes and regulations and are experienced with this type of product.
- B. Before servicing or cleaning the product switch power off at service panel and lock service panel to prevent power from being switched "ON" accidentally.

Routine maintenance is required to keep this product operating at its peak performance and efficiency. Over time, the housing, air intake grille, air intake filter, blower wheels and motor(s) will accumulate a buildup of dust, debris and other residue. It is imperative to keep these components clean. Failure to do so will not only lower operational efficiency and performance, but also reduce the useful life of the product. The time between cleanings depends on the application, location, and daily hours of use. On average, under normal use conditions, the product should require a thorough cleaning once every six (6) months.

To clean the product, perform the following:

1. Verify the product has been disconnected from the power source.
2. Use a damp cloth and either a warm mild soapy water solution or bio-degradable degreaser, to wipe down the exterior components of the housing.
3. To access the interior of the product, remove the air intake grille and/or air intake filter. This is accomplished by removing the eight (8) self-tapping screws on the face of each air intake grille/filter.
4. Thoroughly clean the air intake grille/filter.
5. Remove the motor fan assembly (MFA) from inside the air curtain housing. This is accomplished by loosening the watertight fitting and pulling the cord out (3 phase power) or by the quick disconnect plug on the motor (1 phase power). Then remove the two (2) wing nuts on the out-board sides of the MFA pan. Care should be taken to avoid the MFA from tipping over.
6. Remove the MFA from the unit and thoroughly wipe down the motor, blower wheels and blower wheel housings. Be careful not to submerge the motor in water or spray it with a water hose.
7. The motor(s) require no additional lubrication. They are permanently lubricated and feature double sealed ball bearings.
8. To re-install the product, reverse the procedures above.
9. Reconnect the power source to the product
10. If you have any questions regarding the maintenance of the product, contact the manufacturer.

SPECIAL APPLICATIONS

Outdoor Installation

For outdoor unit special consideration may be required for enclosure, motor, wheel, and other components to minimize damage caused by exposure to the outdoor elements. Contact factory for special construction and costing.

Freezer and Cooler Installation

Air curtain must be mounted on the warm side for optimal performance. Variable Frequency Drive (VFD) is strongly recommended to control the air curtain air flow velocity at the floor level.

High humid areas may require de-humidifier or additional defrost cycle to minimize condensation and freezing for freezer applications. We recommend the air curtain unit to not replace doors but work in conjunction with door opening sequence cycle. Contact factory for details.

CAUTION

The appliance is not to be used by persons (including children) with reduced physical, sensory, or mental capabilities, or lack of experience and knowledge, unless they have been given supervision or instruction. Children are not to play with the appliance.

DISCLAIMER

Mars reserves the right to change specifications and product design without notice. Such revisions do not entitle the buyer to corresponding changes, improvements, additions, or replacements for previously purchased equipment.

TROUBLESHOOTING

PROBLEM	CAUSE	SOLUTION
NO AIR BLOWING OUT OF DISCHARGE NOZZLE	<ul style="list-style-type: none"> - No power being supplied to the unit from the electrical power source - Circuit breaker is tripped - Blown fuses on power supply - Motor overload is open or tripped - Motor contactor / relay defective (if applicable) - Failed switch 	<ul style="list-style-type: none"> - Confirm power source / check if in on position - Reset circuit breaker - Replace fuses - Allow the motor to cool down; motor has auto reset internal overload; if unit is panel equipped, press reset button on overload inside panel, or replace motor overload if overload remains tripped - Check voltage to coil; check contacts to see if they are pulling in - Replace or repair limit switch
MOTOR IS RUNNING BUT FANS ARE NOT SPINNING	<ul style="list-style-type: none"> - Loose or broken coupling (belt drive) - Loose set screws on wheel hubs - Fan spinning inside fan housing - Broken fan hub 	<ul style="list-style-type: none"> - Replace or tighten coupling - Tighten set screws on motor shaft flats - Tighten fan on shaft or replace fan - Replace fan wheels
ELECTRICAL CONTROLS NOT WORKING WHEN DOOR IS OPEN	<ul style="list-style-type: none"> - Switch is in off position - Door limit switch is not operating 	<ul style="list-style-type: none"> - Turn unit's switch to the on position - Repair or replace door limit switch
UNIT WILL NOT TURN OFF	<ul style="list-style-type: none"> - Door limit switch is permanently closed or energized 	<ul style="list-style-type: none"> - Position the door switch in a manner that turns off the unit when the door closes and turns on the unit when the door opens. Only light pressure required.
LOW AIR FLOW	<ul style="list-style-type: none"> - Discharge air vanes out of adjustment - Obstruction on intake or discharge - Power leads out of polarity - Blower motor rotating below normal speed - Fan rubbing against housing - Blower wheels clogged with dirt 	<ul style="list-style-type: none"> - Adjust vanes to proper position (Refer to Start-Up Section in this manual) - Remove obstruction or move air curtain - Switch power leads to correct polarity (3 phase models only) - Apply proper voltage per unit requiremen (see unit label) / Adjust adjustable motor speed knob (if applicable) - Free fan from housing - Clean and remove dirt from blower wheels
EXCESSIVE AIR VELOCITY AT DOOR OPENING	<ul style="list-style-type: none"> - Nozzle out of adjustment and not angled far out enough (BD only) - Air temperature too cold - Air stream pushing air outside of the building 	<ul style="list-style-type: none"> - Adjust nozzle angle to outside - Add auxiliary heat to overcome wind chill - Adjust discharge angle back into building
AIR NOT HITTING THE FLOOR	<ul style="list-style-type: none"> - Low air velocity - Obstruction in the direction of air flow - Negative building pressure 	<ul style="list-style-type: none"> - Adjust vanes to proper position or check installation height (Refer to Start-Up Section in this manual) - Remove obstruction or move air curtain (Move out 3/8" for every 1" up from the door) - Provide a make-up air system to relieve negative building pressure
UNEVEN AIR	<ul style="list-style-type: none"> - Shaft rotating inside fan - One motor not functioning 	<ul style="list-style-type: none"> - Replace fan or tighten fan on shaft - Replace or repair motor
EXCESSIVE NOISE AND OR VIBRATION	<ul style="list-style-type: none"> - Loose or broken coupling (belt drive) - Loose set screws on wheel hubs - Fan spinning inside fan housing - Broken fan hub - Bearing end caps worn - Damaged blower wheel - Bearing end caps worn - Balancing clips missing 	<ul style="list-style-type: none"> - Replace or tighten coupling - Tighten set screws on motor shaft flats - Tighten fan on shaft or replace fan - Replace fan wheels - Replace Bearing end caps - Replace Blower Wheel - Replace Bearing end caps - Replace Blower Wheel

TROUBLESHOOTING MOTOR

To determine if the motor is in good operating condition, compare measured motor resistance at the motor terminals to the values shown below.

MARS MOTOR RESTANCE READINGS										
Single Phase Motors										
 atmosphere is everything								MOTOR WIRES OR TERMINAL (T) OHM READINGS		
								HIGH SPEED (1750)	MEDIUM SPEED (1650)	LOW SPEED (1450)
Applicable Air Curtain Series	Mars Part #	Manufacturer Part #	Brand	Motor Rating	HP	Voltage	Phase	Black Motor Wire & White Motor Wire	-	-
LPV2, LPN2	03-001	7190-1682	Fasco	Nema 1	1/6	115	1	11.5	-	-
	03-002	7190-1903	Fasco	Nema 1	1/6	115	1	8.4	-	-
	03-003	7190-1825	Fasco	Nema 1	1/6	230	1	64	-	-
	03-004	7190-1904	Fasco	Nema 1	1/6	230	1	44.6	-	-
Applicable Air Curtain Series	Mars Part #	Manufacturer Part #	Brand	Motor Rating	HP	Voltage	Phase	White Motor Wire (T1) & Black Motor Wire (T3)	White Motor Wire (T1) & Black Motor Wire (T5)	White Motor Wire (T1) & Black Motor Wire (T2)
STD2, N2, PH10, QP10	03-010	34G928X169	Baldor	Washdown (IP54)	1/2	115	1	1.2	-	-
	03-010	34G928X169	Baldor	Washdown (IP54)	1/2	208/230	1	4.6	-	-
	03-005	7124-1175	Genteq	Nema 1	1/2	115	1	2.6	3.8	5.2
	03-006	7124-1560	Genteq	Nema 1	1/2	208/230	1	9.9	15.9	22.5
	03-007	48S17T439	Marathon	Nema 1	1/2	277	1	7.7	-	-
	03-005	K055PWM1736C13H	Nidec	Nema 1	1/2	115	1	2.1	3.7	5.2
	03-005	K055PWM1736C13H	US	Nema 1	1/2	115	1	5.3	3.7	5.4
03-006		US	Nema 1	1/2	208/230	1	8.7	18.2	24.2	
Applicable Air Curtain Series	Mars Part #	Manufacturer Part #	Brand	Motor Rating	HP	Voltage	Phase	White Motor Wire (T1) & Black Motor Wire (T2)	White Motor Wire (T1) & Black Motor Wire (T3)	-
HV2, NH2, PH12	03-021	35T276R025G1	Baldor	Washdown (IP54)	1	115	1	0.7	-	-
	03-015-Baldor	35M316S174	Baldor	Nema 1	1	115	1	0.6	-	-
	03-015-Baldor	35M316S174	Baldor	Nema 1	1	208/230	1	2.2	-	-
	03-021	35T276R025G1	Baldor	Washdown (IP54)	1	208/230	1	2.8	-	-
	03-014	7124-0985	Genteq	Nema 1	1	115	1	1.6	2.4	-
	03-015	7124-1096	Genteq	Nema 1	1	208/230	1	6.5	9.2	-
	03-015	-	Nidec	Nema 1	1	208/230	1	4.3	6.5	-
	03-014	K55BWJZB-2362	US	Nema 1	1	115	1	1	2.1	-
	03-015	-	US	Nema 1	1	208/230	1	3.2	6.3	-
Three Phase Motors										
Applicable Air Curtain Series	Mars Part #	Manufacturer Part #	Brand	Motor Rating	HP	Voltage	Phase	LEAD WIRE OHM READINGS		
								Black Motor Wire (L1) & Red Motor Wire (L2)	Black Motor Wire (L1) & White Motor Wire (L3)	Red Motor Wire (L2) & White Motor Wire (L3)
STD2, N2, PH10, QP10	03-008	P55YDHB-1527	US	Nema 1	1/2	208-230	3	16.1	16.1	16.1
	03-008	P55YDHB-1527	US	Nema 1	1/2	460	3	63.6	63.6	63.6
	03-009	48T17T135	Marathon	Nema 1	1/2	575	3	136	136	136
HV2, NH2, PH12	03-017	56T17T5541	Marathon	Nema 1	1	208-230	3	4.3	4.3	4.3
	03-017	56T17T5541	Marathon	Nema 1	1	460	3	16.5	16.5	16.5
	03-018	56T17T5544	Marathon	Nema 1	1	575	3	26.6	26.6	26.6
	03-022	35N127S902	Baldor	Washdown (IP54)	1	208-230	3	5.1	5.1	5.1
03-022	35N127S902	Baldor	Washdown (IP54)	1	460	3	19.8	19.8	19.8	
EP2	03-026	165716	Century	Nema 1	3	208-230	3	1.5	1.5	1.5
	03-026	165716	Century	Nema 1	3	460	3	5.7	5.7	5.7
	03-028	35E92Y26	Baldor	Nema 1	3	575	3	9.2	9.2	9.2
WMI	03-110	36H110-2211G1	Baldor	Nema 1	1,2,3	208-230	3	3.5	3.5	3.5
	03-110	36H110-2211G1	Baldor	Nema 1	1,2,3	460	3	13.5	13.5	13.5
WMH	03-055	37F932W828G1	Baldor	Nema 1	5	230	3	0.7	0.7	0.7
	03-055	37F932W828G1	Baldor	Nema 1	5	460	3	2.4	2.4	2.4
	03-046	37F909X889G1	Baldor	Nema 1	7	230	3	0.6	0.6	0.6
	03-046	37F909X889G1	Baldor	Nema 1	7	460	3	1.6	1.6	1.6
BD	03-033	U639A - 215TFC6027	Marathon	Nema 1	10	208-230	3	0.4	0.4	0.4
	03-033	U639A - 215TFC6027	Marathon	Nema 1	10	460	3	1.2	1.2	1.2
	03-074	GT1128A 170118.60	Marathon	Nema 1	25	575	3	0.5	0.5	0.5

WARRANTY

Mars' warranty coverage, period, extent, and limitations apply to the product only. It does not apply to labor. Mars warrants that Mars product 1) Is free from defects in materials and workmanship and 2) Conforms to Mars' published specifications. The warranty period for Mars product except heated and custom models, is a five (5) year period commencing on its date of shipment. The date on customer's invoice is the date of shipment unless Mars or your reseller informs you and Mars otherwise. For heated products, the warranty period is an eighteen (18) month period and for custom products and accessories, the warranty period is twelve (12) months period commencing the date of shipment. Mars will provide free replacement of any part that fails as a result of a defect in material or manufacturer's workmanship. Changes in operational specification parameters that are different from those provided on the original purchase order are not covered. Mars product is inspected and tested before packaging and is shipped in working condition. The warranty for Mars product only covers free-of-charge replacement of failed parts. The warranty does not cover labor and transportation expenses that may be required to provide and to install replacement parts. Because in many instances, it is impossible to determine the cause of failure, customer may be responsible for transportation charges associated with replacement of failed part. Mars does not warrant uninterrupted or error-free operation of Mars product. Under no circumstance is Mars liable for any of the following: 1) Third-party claims against you for damages; or 2) Special, incidental, or indirect damages or for any economic consequential damages (including lost profits and savings), even if Mars, its suppliers, or its reseller is informed of their possibility. The warranty does not cover repair or exchange of Mars product resulting from misuse, accident, modification, unsuitable physical or operating environment, improper maintenance and installation by customer, or failure caused by a product for which Mars is not responsible. The warranty does not cover damages caused by mishandling during transportation. The warranty is voided by removal or alteration of Mars product or parts identification labels, by improper installation of product, and resulting non-compliance to federal, state, and local codes and regulations. Additionally, Mars reserves the right to void the warranty for non-payment of invoice.

CONTACT FACTORY FOR COMPLETE PARTS LIST FOR ALL MODELS.

KEEP THIS MANUAL FOR YOUR RECORDS.

Model Number: _____

Serial Number: _____

Date Purchased: _____

Dealer Purchased From: _____



atmosphere is everything

14716 S. Broadway St., Gardena, CA 90248

(310) 532-1555 • (800) 421-1266

Fax: (310) 324-3030

Please go to our website at www.marsair.com for a downloadable version of this document.

HEATED PRODUCTS SUPPLEMENT

NOTE

Before proceeding, refer to the units specific IOM Manual for safety, installation and start information. Verify proper voltage to the product per local and NEC codes. Ensure proper rotation for units with three phase motors.

Electrically Heated Products

Electrically heated products must be mounted on the inside of the building. Electrically heated products come standard with a thermostat (provided and shipped loose, unless ordered as factory pre-mounted) and is to be field installed at eye level within 3 feet (1 M) of the unit.

Note:

1. Electrically heated Low Profile, Phantom, Standard2, High Velocity2 and Extra Power2 units come with internally mounted controls and comes with 24V control circuit as standard option (FIG. 1) except the Low Profile series that is available with an optional 24V controls with line voltage, 115V or 208-240V controls as typical offering.
2. Wiring connection for the electrically heated Low Profile units is at the top of the housing which can be accessed by removing the top cover plate while internal terminal blocks are provided for electrically heated Phantom, Standard2, High Velocity2 and Extra Power2 units.
3. Electrically heated Wind Stopping and WindGuard units include an electric heater control panel mounted on the right-hand side, as standard. Optional motor/unit control panel available, which includes a remote 24-volt thermostat with On/Off switch with terminals provided.

The thermostat should be mounted as close to the product's discharge air flow as possible in order to best sense the discharged air temperature around the door opening. Connect proper voltage to the product per local and NEC codes.

Thermal overload protection is built into the heater coil assembly/assemblies. In the event of an overload condition, electrical power will be disconnected from the heater coil. Upon diagnosing the problem, electrical power can be re-instated to the heater coil(s) by manually resetting the thermal overload lever(s) or buttons(s) located in the unit or panel.

To operate multiple units mounted side by side, utilizing a single door switch and single thermostat, a master/slave configuration is required. (FIG. 2)

For high ampacity units, new holes can be drilled to bring in electrical wires. Use appropriate bushing for new holes to protect wire casing. High temperature silicon wires would be recommended for main supply power.

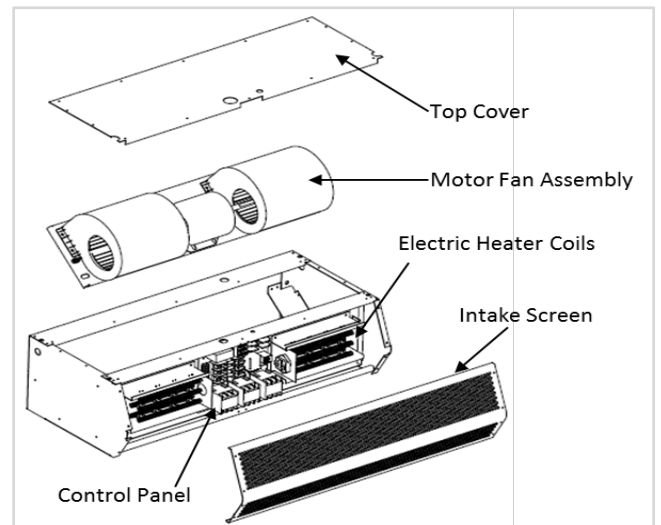

FIG. 1 (Electrically Heated STD2 unit)

Unobstructed clearance space of 18"-24" must be provided at the top of air curtain for performance and service for all heated air curtain.

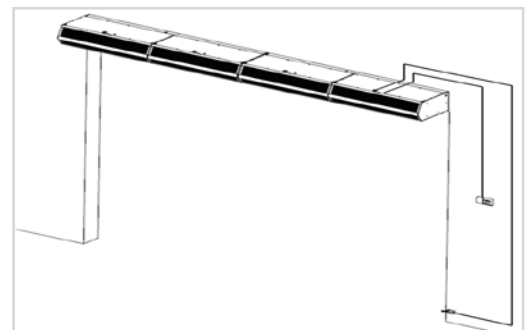

FIG. 2 (Tandem Mounted Master/Slave Units)

Steam and Hot Water Coil Heated Products

Steam/Hot Water Coil (coil) heated products must be mounted on the inside of the building. The coil(s) for Low Profile, Standard, High Velocity, Extra Power and Phantom units are shipped internally mounted to the unit. Wind Stopping and WindGuard units are shipped with coil(s) factory mounted.

Once the coil has been secured to the cabinet, access to the motor and fan is through the removable access panels located on the top of the cabinet for Standard, High Velocity, Extra Power and Phantom units.

Note: Low Profile and Wind Stopping units require the removal of the coil to access the motor and/or fans.

All piping should be done by a licensed pipe fitter and in accordance with local codes and regulations. Connect the supply and return fittings as required. All traps and valves are sized and field-installed by others. For Standard, High Velocity and Extra Power units, front intake screen must be removed to access vent plugs. Standard coil configuration is right hand supply and left-hand return. (FIGS. 3 & 4) Optional temperature controls, if ordered, are to be field installed by others.

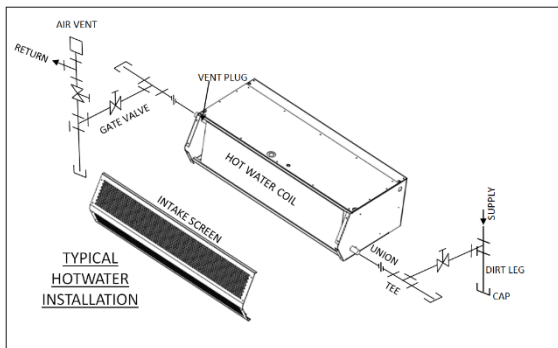

FIG. 3 (Hot Water Heated STD Unit)

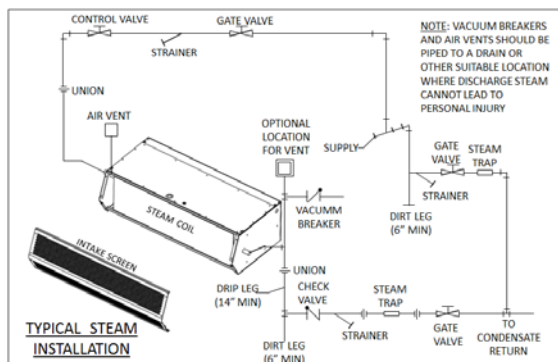

FIG. 4 (Steam Heated STD Unit)

Gas Heated Products

Gas heated products must be mounted on the inside of the building. The product consists of three major components: the air curtain, transition section(s) and indirect gas fired duct furnaces(s) (FIG 5).

The transition section(s) are shipped knocked down and are to be field assembled and installed per their supplemental instructions. (FIG. 6) (Exceptions are WMI/H and BD series, fully assembled transitions are provided).

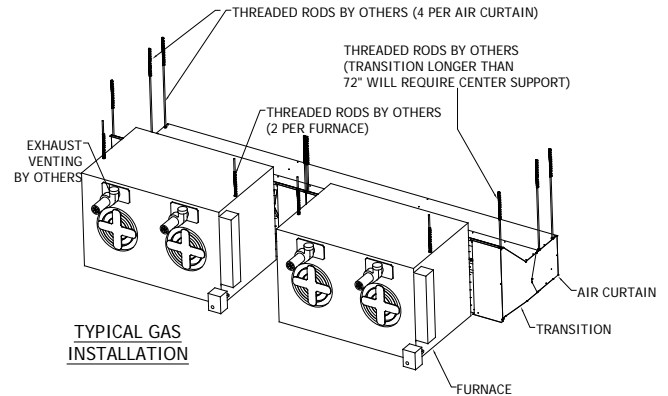

FIG. 5 (Indirect Fired Gas Heated HV Unit)

Note:

1. Assemble the transition section(s).
2. Measure the width of the transition section(s) to determine the installation location for the duct furnace(s).
3. The duct furnace(s) are typically hung from above, with threaded rods, in order to support the weight of the duct furnaces. The duct furnace(s) must be centered and equally spaced with a 2" clearance between furnaces and the transition(s).
4. Move the adjustable blank off plates to close gaps in the transition(s) and secure the flanges to the transitions.

All gas piping and duct furnace(s) exhaust venting should be done by a licensed pipe fitter and in accordance with local codes and regulations. Power vented exhaust duct runs should not exceed 100' for horizontal venting. See furnace installation manual for piping and other details.

FIG. 6 (Transition Kit Exploded View)

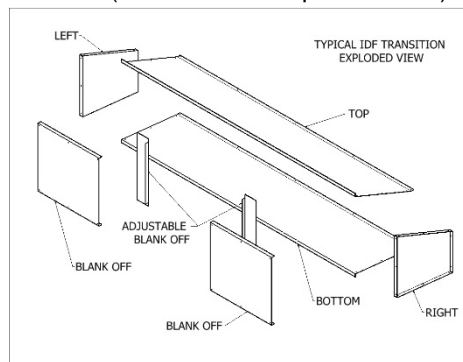

In the United States, installation must conform with local codes or, in the absence of local codes, with Installation of the National Fuel Gas Code, ANSI Z223.1-latest edition, from the American

National Standard Institute. Further reference should be made to the recommendation of your fuel supplier. In Canada, Installation must conform with local codes or, in the absence of local codes, with Installation Codes for Gas Burning Appliances and Equipment, CGA Standard CAN/CGA 1B-149. Further reference should be made to the recommendation of your fuel supplier.



atmosphere is everything

SECTION 23 34 33

AIR CURTAINS

Important Note: This specification contains hidden text appearing in red. To show or remove hidden text in MSWord, click the "File" tab or "Office" icon on the top-left corner, select "Options," select "Display," and check or uncheck the box marked "Hidden Text."

PART 1 GENERAL

1.1 SECTION INCLUDES

- A. Air curtains for pedestrian entrances.
- B. Air curtains for vehicular entrances.
- C. Air curtains for large loading dock doors.

1.2 RELATED SECTIONS

- A. Section 05 50 00 – Metal Fabrications: Concealed steel support members.
- B. Section 06 10 00 – Rough Carpentry.
- C. Section 05 41 00 – Structural Metal Studs.
- D. Section 07 62 00 – Sheet metal flashing.
- E. Section 07 92 00 – Joint Sealants.
- F. Section 08 10 00 – Metal Doors and Frames.
- G. Section 08 33 00 – Overhead Coiling Doors.
- H. Section 08 42 00 – Entrance Doors.
- I. Section 22 10 00 – Plumbing Piping:
- J. Section 23 21 00 – Hydronic Piping: Hot water heating piping to units.

- K. Section 23 22 13- Steam and Condensate Piping: Steam heating piping to units.
- L. Section 26 05 00 – Equipment Wiring: Connections to building power distribution.

1.3 REFERENCES

- A. ASTM A240 / A240M -10 – Standard Specification for Chromium and Chromium.
- B. ASTM A879 / A879M -06 – Standard Specification for Steel Sheet, Zinc Coated by the Electrolytic Process for Application Requiring Designation of the Coating Mass on Each Surface.
- C. ASTM A653 / A653M -09a – Standard Specification for Steel Sheet, Zinc Coated (Galvanized) or Zinc-Iron Alloy-Coated (Galvannealed) by the Hot-Dip Process.
- D. UL 507 – UL Standard for Safety Electric Fans – Intertek Testing Services Listed for US and Canada.
- E. UL508A – Standard for Industrial Control Panels
- F. UL 1995/CSA 22.2 – UL Standard for Safety Heating and Cooling Equipment – Intertek Testing Services Listed for US and Canada.
- G. UL 2021/CSA 22,.2 – Standard for Fixed and Location-Dedicated Electric Room Heaters – Intertek Testing Services Listed for US and Canada.
- H. AHRI 410-2001 – Standard for Forced-Circulation Air-cooling and Air-Heating Coils.
- I. NSF/ANSI 37 – Air Curtains for entranceways in food and food service establishments – ETL Sanitation.
- J. AMCA 211 (Air Movement & Control Association International, Inc.) – Certified Ratings Program – Product Rating Manual for Fan Air Performance.
- K. CEC – Approved Elec heating Coils
- L. Electrical components UL/CUL listed.
- M. NEC – National Electric Code.
- N. U.S. Green Building Council, LEED Building Design and Construction (BD+C) Version 4.0 Rating System. (LEED v4.0).

1.4 SUBMITTALS

- A. Submit under provisions of Section 01 33 00.
- B. Product Data: Manufacturer's data sheets on each product to be used, including:
 - 1. Preparation instructions and recommendations.

2. Storage and handling requirements and recommendations.
 3. Installation methods.
- C. Shop Drawings: Include plans, elevations, sections, and details, indicating dimensions, tolerances, materials, fasteners, hardware, finish, piping, electrical wiring diagrams, options, and accessories.
- D. LEED Submittals: Provide documentation of how the requirements of Credit will be met:
1. List of proposed materials with recycled content. Indicate post-consumer recycled content and pre-consumer recycled content for each product having recycled content.
 2. Product data and certification letter indicating percentages by weight of post-consumer and pre-consumer recycled content for products having recycled content.
- E. Selection Samples: For each finish product specified, two complete sets of color chips representing manufacturer's full range of available colors and patterns.
- F. Verification Samples: For each finish product specified, two samples, minimum size 6.25 inches (160 mm) square, representing actual product, color, and patterns.
- G. Manufacturer's Certificates: Certify products meet or exceed specified requirements.
- H. Operation and Maintenance Manual: Submit manufacturer's operation and maintenance manual, including operation, maintenance, adjustment, and cleaning instructions, trouble shooting guide, parts list, and electrical wiring diagrams.

1.5 QUALITY ASSURANCE

- A. Manufacturer Qualifications: Minimum ten years documented experience producing the products specified in this Section
- B. Installer Qualifications: Minimum five years documented experience installing products specified in this Section

1.6 DELIVERY, STORAGE, AND HANDLING

- A. Store products in manufacturer's unopened packaging until ready for installation.
- B. Store in a dry, heated storage area until installation of products.
- C. Protect materials and finish from damage during handling and installation.

1.7 SEQUENCING

- A. Ensure that locating templates and other information required for installation of products of this section are furnished to affected trades in time to prevent interruption of construction progress.

- B. Coordinate the installation of wiring and control switches for air curtains with the openings and the hardware provided for such openings.
- C. Install after doors, walls, ceilings, and other adjacent surfaces are finished and painted.

1.8 WARRANTY

- A. Standard five-year limited parts warranty for unheated units against defects in workmanship and material.
- B. Standard 18-month limited parts warranty for heated units against defects in workmanship and materials.

PART 2 PRODUCTS

2.1 MANUFACTURER

- A. Acceptable Manufacturer: Mars Air Systems, LLC; 14716 South Broadway St., Gardena, CA 90248. Tel: (310) 532-1555 or (800) 421-1266. Fax: (310) 324-3030. Email: info@marsair.com. Web: www.marsair.com.
- B. Delete one of the following two paragraphs: coordinate with requirements of Division 1 section on product options and substitutions.
- C. Requests for substitutions will be considered in accordance with provisions of Section 01 33 00.

2.2 AIR CURTAIN ASSEMBLIES

- A. Motor Fan Assembly: Design for easy removal, assembly, repair, and maintenance.
 - 1. Motor: Totally enclosed air over (TEAO) cooled motor with sealed lifetime pre-lubricated ball bearings, motor starter and thermal overload protection.
 - a. Wired for single speed operation.
 - b. Wired for two speed operation. (Not Applicable for Fly Insect Control Unit)
 - c. Wired for three speed operation. (Not applicable for Fly Insect Control Unit)
 - d. Provide wash down type motors, NEC IP-54 for the locations indicated.
 - e. Provide explosion proof type motors, NEC Class 1, Division 1, Group D for the locations indicated.
 - f. Electrical Characteristics: 115V AC, single phase; 5.1 Amp full load per motor/fan.
 - g. Electrical Characteristics: 208/230V AC, single phase; 2.5 Amp full load per motor/fan.
 - h. Electrical Characteristics: 208/230V AC, three-phase; 1.8/1.6 Amp full load per motor/fan.
 - i. Electrical Characteristics: 460V AC, three-phase; 0.8 Amp full load per motor/fan.

- j. Electrical Characteristics: 575V AC, three-phase; 0.65 Amp full load per motor/fan.
 - k. Meets NEC. ETL Listed to conform to UL 507 (US) and CSA22.2 (Canada) Standards. AMCA 211 Certified.
 - 2. Fans: Forward curved centrifugal type, double width, and double inlet design, directly driven to an electric motor.
 - a. Provide resilient isolation dampening mountings between motor frame and motor mounting pan.
 - b. Factory balanced blower wheel assembly statically and dynamically.
 - B. Housing: Self-contained one-piece type with sufficient strength for mounting from pre-punched mounting holes at both ends to adjacent walls or ceiling without intermediate support.
 - 1. Size:
 - a. Unheated: 12-3/4 inches deep by 10-5/8 inches high (including discharge nozzle) by width of unit.
 - b. Electric Heated: 17-3/8 inches deep by 10-5/8 inches high (including discharge nozzle) by width of unit.
 - c. Hot Water/Steam Heated: Depth 17-3/8 inches single row and double row by 10-5/8 inches high including discharge nozzle by width of unit plus 10 inches for manifolds.
 - 2. Mounting:
 - a. Unheated Inside Mount.
 - b. Heated Inside Mount.
 - c. Unheated Outside Mount.
 - d. Mount Location Indicated.
 - 3. Material:
 - a. Provide 18- and 20-gauge electro or hot dipped galvanized steel sheet housing conforming to ASTM A 879 and/or ASTM A 653.
 - b. Provide type 304 stainless steel housing with brushed finish. ASTM A 240/A 240M.
 - 4. Air Inlet Grille and/or Filters: Provide air inlet grille and/or filters specified.
 - 5. Discharge: Provide integral discharge nozzle specified.
 - 6. Finish and Color: Provide with, no VOC, corrosion resistant polyurethane powder coated finish for sheet metal housings.
 - a. Obsidian Black.
 - b. Pearl White.
 - c. Titanium Silver.
 - d. Stainless Steel.
 - C. Environmental Air Curtains: Models for Heights to 12 feet (3656 mm) for Environmental Separation and Temperature Control and up to 10 feet (3048 mm) for Flying Insect Control (STD2 series)
 - 1. Discharge Nozzle: Wedge-shaped discharge outlet nozzle with adjustable air foil vanes with a plus/minus 40-degree sweep front to back.
 - 2. Air Velocity at Nozzle:
 - a. STD236-1: 36 Inch (915 mm) Wide Units: 2206 feet/min (11.2 m/s) single 1/2HP motor/fan assembly.

- b. STD242-1: 42 Inch (1065 mm) Wide Units: 1945 feet/min (9.9 m/s) single 1/2HP motor/fan assembly.
 - c. STD248-1: 48 Inch (1220 mm) Wide Units: 1730 feet/min (8.8 m/s) single 1/2HP motor/fan assembly.
 - d. STD260-2: 60 Inch (1524 mm) Wide Units: 2592 feet/min (13.2 m/s) single 1/2HP motor/fan assembly.
 - e. STD272-2: 72 Inch (1830 mm) Wide Units: 2206 feet/min (11.2 m/s) two 1/2HP motor/fan assemblies.
 - f. STD284-2: 84 Inch (2133 mm) Wide Units: 1945 feet/min (9.9 m/s) two 1/2HP motor/fan assemblies.
 - g. STD296-2: 96 Inch (2440 mm) Wide Units: 1730 feet/min (8.8 m/s) two 1/2HP motor/fan assemblies.
 - h. STD2108-3: 108 Inch (2743 mm) Wide Units: 2206 feet/min (11.2 m/s) two 1/2HP motor/fan assemblies.
 - i. STD2120-3: 120 Inch (3050 mm) Wide Units: 2084 feet/min (10.6 m/s) three 1/2HP motor/fan assemblies.
 - j. STD2144-3: 144 Inch (3660 mm) Wide Units: 1730 feet/min (8.8 m/s) three 1/2HP motor/fan assemblies.
3. Air Speed at Floor: Minimum of 300 fpm (1.53 m/s) at 3 feet (914 mm) from the floor.
 4. Air Inlet Grille and Filters:
 - a. Location: Front.
 - b. Type: Fixed air intake grille.
 - 1) Filter: Aluminum mesh, 1/4 inch (6.4 mm), washable.
 - c. Type: Filter Only as follows:
 - 1) Filter: Flat bank 1-inch, disposable.
 - 2) Filter: Flat bank 2-inch, disposable.
 - 3) Filter: Aluminum mesh, 1/4 inch (6.4 mm), washable.
 - 4) Filter: HEPA filtration, 12" HEPAC section with disposable filters
 - d. Type: UV Only as follows
 - 1) UV: UVC & UVV germicidal and odor elimination, 5-1/2" UV section with disposable UV bulbs
 - e. Speed: 2550 cu ft/min (1200 L/s), minimum, per motor/fan assembly.
 5. Sound Pressure Level At 10 feet (3 m) From Nozzle:
 - a. Single Motor/Fan Units: 66 dBA.
 - b. Two Motor/Fan Units: 68 dBA.
 - c. Three Motor/Fan Units: 71 dBA.
 - d. Four Motor/Fan Units: 73 dBA.
- D. Insect Control Air Curtains: Models for Heights up to 7 feet (3048 mm) for Flying Insect Control. Certified to NSF/ANSI Standard 37. (N2 Series)
1. Discharge Nozzle: Wedge-shaped discharge outlet nozzle with adjustable air foil vanes with a plus/minus 40-degree sweep front to back.
 2. Air Velocity at Nozzle:
 - a. N236-1: 36 Inch (915 mm) Wide Units: 2206 feet/min (11.2 m/s) single 1/2HP motor/fan assembly.

- b. N242-1: 42 Inch (1065 mm) Wide Units: 1945 feet/min (9.9 m/s) single 1/2HP motor/fan assembly.
 - c. N248-1: 48 Inch (1220 mm) Wide Units: 1730 feet/min (8.8 m/s) single 1/2HP motor/fan assembly.
 - d. N260-2: 60 Inch (1524 mm) Wide Units: 2592 feet/min (13.2 m/s) single 1/2HP motor/fan assembly.
 - e. N272-2: 72 Inch (1830 mm) Wide Units: 2206 feet/min (11.2 m/s) two 1/2HP motor/fan assemblies.
 - f. N284-2: 84 Inch (1830 mm) Wide Units: 1945 feet/min (9.9 m/s) two 1/2HP motor/fan assemblies.
 - g. N296-2: 96 Inch (2440 mm) Wide Units: 1730 feet/min (8.8 m/s) two 1/2HP motor/fan assemblies.
 - h. N2108-3: 108 Inch (2743 mm) Wide Units: 2206 feet/min (11.2 m/s) two 1/2HP motor/fan assemblies.
 - i. N2120-3: 120 Inch (3050 mm) Wide Units: 2084 feet/min (10.6 m/s) two 1/2HP motor/fan assemblies.
 - j. N2144-3: 144 Inch (3600 mm) Wide Units: 1730 feet/min (8.8 m/s) two 1/2HP motor/fan assemblies.
3. Air Speed at Floor:
 - a. Customer entry doors require a minimum of 600 fpm (3.05 m/s) at 3 feet (914 mm) from floor.
 4. Air Inlet Grille and Filters:
 - a. Location: Front.
 - b. Speed: 2550 cu ft/min (1200 L/s), minimum, per motor/fan assembly.
 - 1) Type: Fixed air intake grille.
 5. Sound Pressure Level At 10 feet (3 m) From Nozzle:
 - a. Single Motor/Fan Units: 66 dBA.
 - b. Two Motor/Fan Units: 68 dBA.
 - c. Three Motor/Fan Units: 71 dBA.
 - d. Four Motor/Fan Units: 73 dBA

2.3 COMPONENTS

- A. Electric Heaters: Provide complete with motor control panel factory mounted to air curtain housing, and thermostat to be field installed
 1. Temperature limit controller.
 2. Thermostat: Wall-mounted, 24-Volt operation, with heater on/off selection.
 3. Heating Coils: ETL approved as part of unit. Meets NEC and CEC tested by ETL Certified to conform to UL2021(US) and CSA22.2 (Canada) Standards. Factory mounted on the discharge end of the motor fan assembly and located within the nozzle outlet.
- B. Steam Heaters: Provide finned tube steam coils for field mounting on air intake side of the air curtain cabinet with opposite end connections.
 1. Meets NEC and CEC tested by ETL Certified to conform to UL1995(US) and CSA22.2 (Canada) Standards.
 2. Output: Air curtain manufacturer's standard, one-row coils.
 3. Coils: Certified in accordance with AHRI 410.
 4. Connections: Opposite end.

5. Connections: Same end, right hand.
 6. Connections: Same end, left hand.
 7. Casing: One-piece unpainted galvanized steel, bolted to air curtain housing.
 8. Supply and return fittings on ends of casing.
 9. Steam Distributing coil required for 8 feet and above for same end coils. Dual supply, Single returns.
 10. Thermostat: Wall-mounted, 110-Volt operation, with heater on/off selection.
 11. Thermostat: Wall-mounted, 208/230-Volt operation, with heater on/off selection.
- C. Hot Water Heaters: Provide finned tube water coils for field mounting on air intake side of the air curtain cabinet with opposite end connections.
1. Meets NEC and CEC tested by ETL Certified to conform to UL1995(US) and CSA22.2 (Canada) Standards.
 2. Output: Air curtain manufacturer's standard, one-row coils.
 3. Output: Air curtain manufacturer's standard, two-row coils.
 4. Coils: Certified in accordance with AHRI 410.
 5. Connections: Opposite end.
 6. Connections: Same end, right hand.
 7. Connections: Same end, left hand.
 8. Casing: One-piece unpainted galvanized steel, bolted to air curtain housing.
 9. Supply and return fittings on top of casing.
 10. Thermostat: Wall-mounted, 110-Volt operation, with heater on/off selection.
 11. Thermostat: Wall-mounted, 208/230-Volt operation, with heater on/off selection.
- D. Motor Control Panels for Unheated Units: Recommended for all three-phase units and single phase units with combined motor capacities of more than 1 HP whenever a door limit switch is used to automatically start and stop the air curtain. Provide motor control panels as follows:
1. Mounting: Shipped loose to be field mounted.
 2. Mounting: Factory mounted on right hand side of air curtain housing.
 3. Mounting: Factory mounted on left hand side of air curtain housing.
 4. Electrical components UL/CUL listed.
 5. Panels UL 508A listed.
 6. Optional Digital Programmable Controller:
 - a. Remote Mounted High Resolution 5" Color LCD Display with Capacitive Touch technology
 - b. Fully programmable controller
 - c. Pre-set and fully customizable programs
 - d. Time delay (Passive & Adaptive)
 - e. 24/7 timer
 - f. Maintenance schedule alerts
 - g. Status display showing date, time, temperature, and air curtain mode
 - h. Multi-unit control capability
 - i. English (IP) or Metric (SI) display readings
 - j. Password protected
 - k. Auto Lock display
 - l. Emergency shut-off button
 - m. Low voltage control signal for door activation

- n. Integrated BMS controls
 - o. VFD compatible with 0-10VDC output
 - p. Optional BACnet option
 - q. Optional adaptive fan speed control based on existing field conditions. Field mounted outdoor temperature sensors required.
- E. Motor Control Panels for Electric Heated Units: Recommended for all three-phase units and single-phase units with combined motor capacities of more than 1 HP whenever a door limit switch is used to automatically start and stop the air curtain. Motor Control Panel is included for all electric heated units. Thermostat is provided for field installation. Provide motor control panels as follows:
- 1. Mounting: Factory mounted on the inside of air curtain housing.
 - 2. Mounting: Factory mounted on left hand side of air curtain housing.
 - 3. Electrical components UL/CUL listed.
 - 4. Optional Digital Programmable Controller:
 - a. Remote Mounted High Resolution 5” Color LCD Display with Capacitive Touch technology
 - b. Fully programmable controller
 - c. Pre-set and fully customizable programs
 - d. Time delay (Passive & Adaptive)
 - e. Factory Integrated temperature control sensors. No external thermostat required.
 - f. Summer-Winter modes
 - g. 24/7 timer
 - h. Maintenance schedule alerts
 - i. Status display showing date, time, temperature, and air curtain mode
 - j. Multi-unit control capability
 - k. English (IP) or Metric (SI) display readings
 - l. Password protected
 - m. Auto Lock display
 - n. Emergency shut-off button
 - o. High temperature lock from fan failure
 - p. Low voltage control signal for door activation
 - q. Integrated BMS controls
 - r. VFD compatible with 0-10VDC output
 - s. Optional BACnet option
 - t. Optional adaptive fan speed control and heat control based on existing field conditions. Field mounted outdoor temperature sensors required.
- F. Motor Control Panels For Hot Water, Steam and Gas Heated Units: Recommended for all three-phase units and single phase units with combined motor capacities of more than 1HP whenever a door limit switch is used to automatically start and stop the air curtain. Provide motor control panels as follows:
- 1. Mounting: Shipped loose to be field mounted.
 - 2. Mounting: Factory mounted on right hand side of air curtain housing.
 - 3. Mounting: Factory mounted on left hand side of air curtain housing.
 - 4. Provide with remote mount thermostat for field installation.
 - 5. Electrical components UL/CUL listed.

6. Optional Digital Programmable Controller:
 - a. Remote Mounted High Resolution 5" Color LCD Display with Capacitive Touch technology
 - b. Fully programmable controller
 - c. Pre-set and fully customizable programs
 - d. Time delay (Passive & Adaptive)
 - e. Factory Integrated temperature control sensors. No external thermostat required.
 - f. Summer-Winter modes
 - g. 24/7 timer
 - h. Maintenance schedule alerts
 - i. Status display showing date, time, temperature, and air curtain mode
 - j. Multi-unit control capability
 - k. English (IP) or Metric (SI) display readings
 - l. Password protected
 - m. Auto Lock display
 - n. Emergency shut-off button
 - o. High temperature lock from fan failure
 - p. Low voltage control signal for door activation
 - q. Integrated BMS controls
 - r. VFD compatible with 0-10VDC output
 - s. Optional BACnet option
 - t. Optional adaptive fan speed control and heat control based on existing field conditions. Field mounted outdoor temperature sensors required.

- G. Door-Activated Limit switch(s): Provide, field installed 250-Volts, 20 amps limit switch to control air curtain(s) as follows; Automatic on/off control, activates air curtain when door is opened and turns off when door is closed. Provide limit switch for direct control one 1 HP or up to two 1/2 HP single phase motors without a separate control panel. Provide a separate control panel for three-phase motors controlled by a limit switch.
 1. Type: Combination plunger/roller switch for swing and sliding doors.
 - a. Provide limit switches with NEMA 1 (20 amps) ratings in locations indicated.
 - b. Provide limit switches with NEMA 4X (10 amps) ratings in locations indicated.
 - c. Provide limit switches with NEMA 4X (15 amps) ratings in locations indicated.
 - d. Provide limit switches with NEMA 7 (10 amps) ratings in locations indicated.
 2. Type: Magnetic reed switch and actuator for swing and sliding doors. Industrial floor mounted or surface mounted switches for roll up doors.
 3. Operation for Unheated Units: Automatic on/off control, on when door is opened, off when door is closed.
 4. Operation for Heated Units: Automatic on when door is opened, off after time delay period after door is closed, maintaining heat in the event door is opened within time delay period. Field adjustable from 1 to 17 minutes.

- H. Provide mounting hardware as required for the opening.

PART 3 EXECUTION

3.1 EXAMINATION

- A. Verify that required utilities are in correct location and are of correct capacities for specified products.
- B. Verify openings to receive air curtains are plumb, level, square, accurately aligned, correctly located, and in tolerance.
- C. Examine surfaces to receive air curtains. If surface preparation is the responsibility of another installer, notify Architect of unsatisfactory preparation before proceeding.

3.2 INSTALLATION

- A. Install air curtains in accordance with approved shop drawings and manufacturer's printed installation instructions.
- B. Install air curtains plumb, level, square, true to line, and weathertight, without warp or rack.
- C. Anchor air curtains securely in place to supports.
- D. Coordinate with sheet metal flashing as specified in Section 07 62 00.
- E. Install joint sealants as specified in Section 07 92 00.
- F. Coordinate with electrical power as specified in Section 26 05 00.
- G. Install door limit switches and adjust for correct operation.
- H. Provide connection to piped services and utilities as specified in Section 22 10 00 and 23 21 00.

3.3 FIELD QUALITY CONTROL

- A. Adjust air curtains to function properly.
- B. Adjust air foil vanes located within the discharge nozzle as required for prevailing conditions at each opening.
- C. Check heated air curtain performance on a calm day by measuring air temperature 6 inches off the floor. Optimal reading is halfway between the temperature inside and outside the building.

3.4 CLEANING

- A. Clean air curtains promptly after installation in accordance with manufacturer's instructions.

- B. Repair minor damages to finish in accordance with manufacturer's instructions and as approved by Architect.
- C. Remove and replace damaged components that cannot be successfully repaired as determined by Architect.

3.5 PROTECTION

- A. Protect materials and finish from damage until substantial completion.

3.6 SCHEDULES

- A. Refer to Air Curtain Schedule appended to this section.

END OF SECTION



Reference Links

Link

Description

<https://marsair.com/>

Main website

<https://marsair.com/document-library>

**Submittals for all Mars Air Curtains,
Accessories, Installation, and Brochures**

<https://www.marsair.com/Content/Downloads/CSISpecs/STD2-N2-CSI-Specification.doc>

STD2 Series CSI spec (Word doc)