



HV2 Submittal Package

atmosphere is everything

14716 S. BROADWAY, GARDENA, CA 90248 • Ph: (310)532-1555 Fax: (310)-532-3030 • www.marsair.com
© Copyright Mars Air Systems, LLC 2014

HV2 Unheated Series 2

High Velocity Series 2
Air Curtain
Submittal Package

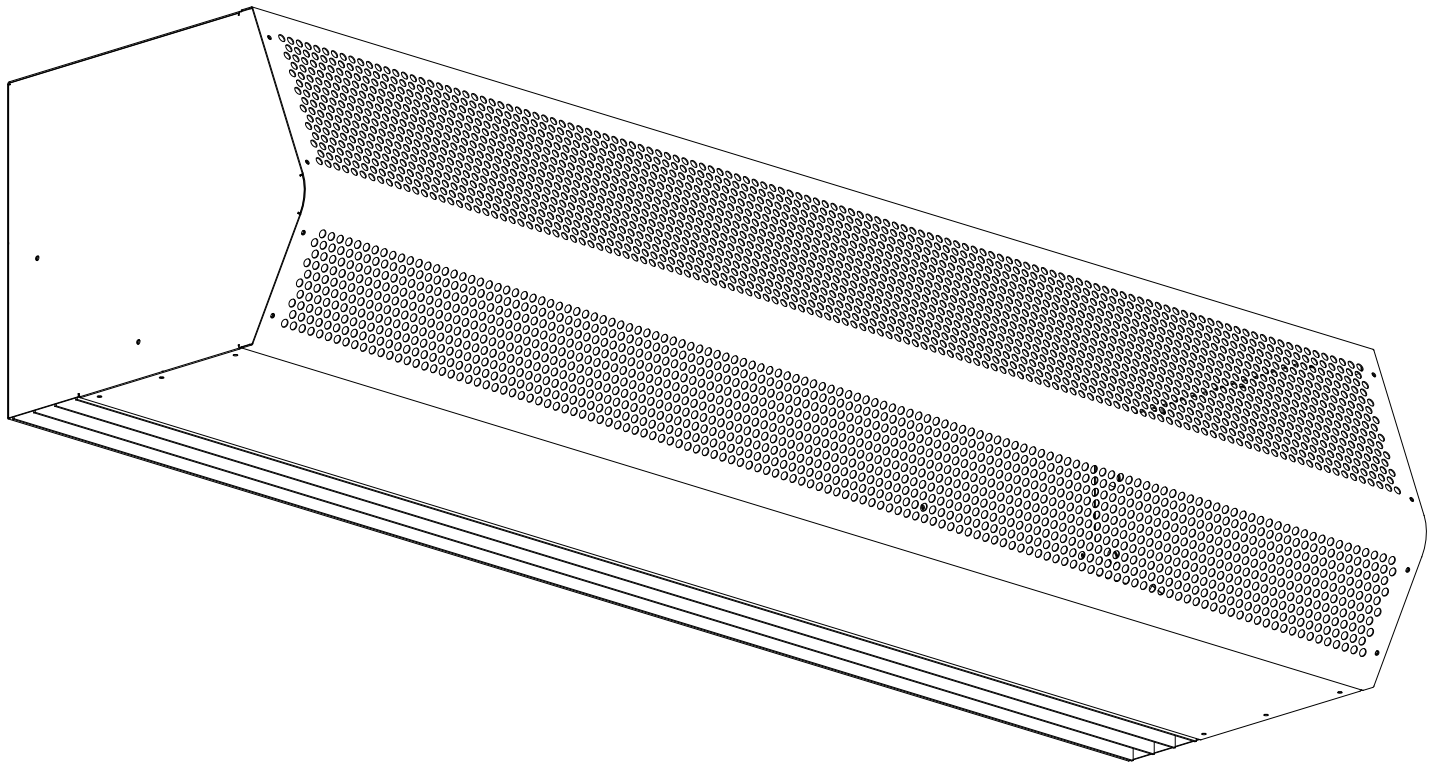

Submitted by:
Mars Air Systems, LLC
14716 S. Broadway
Gardena, CA 90248

P.O.#	
S.Q.	
Company	
Print Name	
Signature	
Date	

Company Seal or Stamp

(Electronic Signature Preferred)

NOTE: MARS AIR SYSTEMS, LLC reserves the right to change specifications and product design without notice. Such revisions do not entitle the buyer to corresponding changes, improvements, additions, or replacements for previously purchased equipment.



Table of Contents

<u>Page #</u>	<u>Content</u>
3-4	HV2 Unheated Submittals
5	Typical Motor Control Panel Wiring Diagram
6-7	Accessory Installation Supplement
8-11	Installation, Operation and Maintenance
12-13	Troubleshooting Guide
14	Warranty
15-26	CSI Spec
27	Reference Links



atmosphere is everything

14716 S. Broadway • Gardena, CA 90248 • USA
 TEL: (310) 532-1555 • (800) 421-1266 • FAX: (310) 324-3030
 Web Site: www.marsair.com • E-mail: info@marsair.com

PROJECT		OPTIONS/ITEMS	
TITLE			
COMMENTS		DATE 7/24/15	PAGE
		REV. NO	
MODEL NO. HV2 Series	DRAWING NO HV2U-F	DRAWN BY FRC	CHECKED BY
		FILE NAME	

Unheated Drawing

HV2 (High Velocity 2) Series

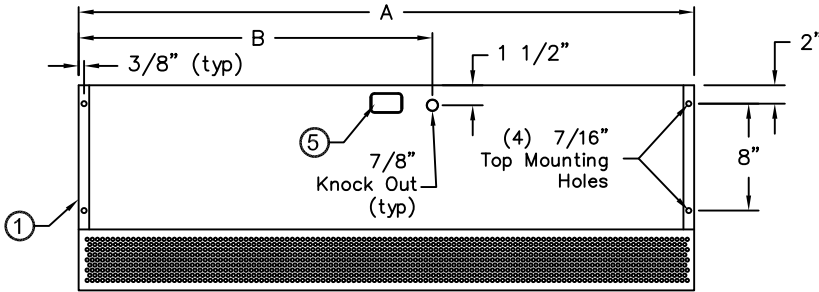
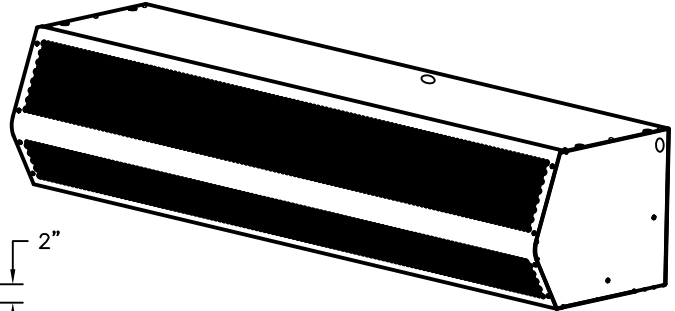

TOP VIEW

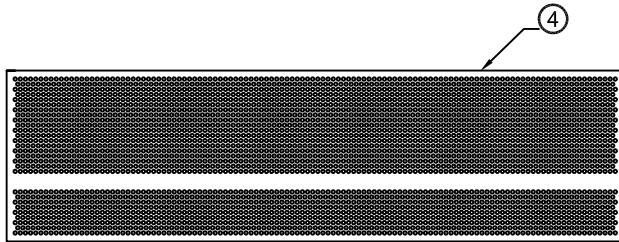

FRONT VIEW

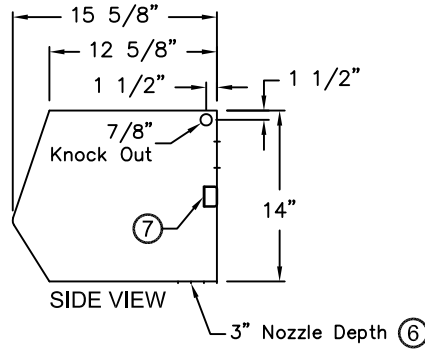

SIDE VIEW

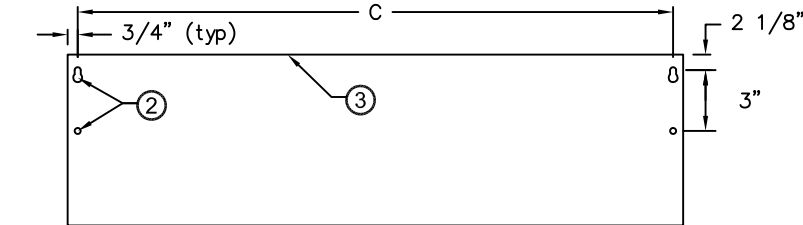

REAR VIEW



Note: Models HV260-1 & HV2120-2 are not AMCA Certified.



⑧ Recommended Accessories



Control Panels



Door Limit Switches

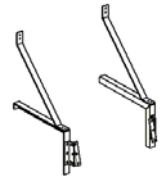

Brackets

*- Use corresponding letters in "Electrical Data" columns to complete the model numbers.

Notes:

- This product is designed to meet the National Electric Code (NEC), ETL Listed (UL 507 and CSA 22.2) and AMCA 211 Certified.
- (2) 1/2" key hole slots and (2) 7/16" mounting holes provided on for wall mounting and (4) 7/16" mounting holes for overhead mounting provided, (2) on each end.
- All units have a self contained one piece cabinet, fire retardant and corrosion proof paint lock metal double protected with baked on Titanium Silver color, rust preventative electrostatic polyurethane powder coating.
- Cabinet has sufficient strength for fastening to wall on both ends without intermediate support.
- Internal J-Box(es) for electrical wiring: one motor-(1) 2"x 4"; two motors-(1) 4"x 4"; three motors-(2) 4"x 4".
- Unit is to be installed such that air flow is unobstructed. Air discharge nozzle containing adjustable air directional vanes with 40° sweep front to back.
- Circuit protection as per NEC by others.
- Optional motor control panel, door limit switch and mounting brackets are field installed and/or wired by others. The door limit switch is to be mounted such that the air curtain turns on as door begins to open. To prevent unit damage, the mounting brackets must be installed such that the bottom of the air curtain is not below the door header.

MODEL NUMBER	OVERALL LENGTH A (in)	KNOCKOUT LOCATION B (in)	REAR MOUNTING CENTER C (in)
HV236-1U*-TS	36	25 1/2	35
HV242-1U*-TS	42	28 1/2	41
HV248-1U*-TS	48	31 1/2	47
HV260-1U*-TS	60	37 1/2	59
HV272-2U*-TS	72	40	71
HV284-2U*-TS	84	46	83
HV296-2U*-TS	96	52	95
HV2108-3U*-TS	108	58	107
HV2120-2U*-TS	120	64	119
HV2120-3U*-TS	120	64	119
HV2144-3U*-TS	144	76	143

HV2 (High Velocity 2) Series

Unheated

Model Lengths 36" – 144"



atmosphere is everything

14716 S. BROADWAY, GARDENA, CA 90248 • Ph: (310)532-1555 Fax: (310)-532-3030 • www.marsair.com
© Copyright Mars Air Systems, LLC 2014

Unheated Data Sheet

Applications: Environmental Separation (up to 14') and Insect Control (up to 12')

HV2 (High Velocity) Series 2	Mechanical Data						AMCA Certified Lab Data				
	Model Number	Nozzle Length (in)	Length (in)	Depth (in)	Height (in)	Motor (hp)	Weight (lbs)	Max Core Velocity at Nozzle (fpm)	Avg Velocity (fpm)	Volume (cfm)	Uniformity (%)
HV236-1U*-TS	36	36	16.0	14	1	115	6000	2745	2059	90	1245
HV242-1U*-TS	42	42	16.0	14	1	120	6051	2654	2322	93	1305
HV248-1U*-TS	48	48	16.0	14	1	125	6144	2447	2447	88	1360
HV260-1U*-TS	60	60	16.0	14	1	140	6330	2208	2760	80	1560
HV272-2U*-TS	72	72	16.0	14	Two 1	220	6000	2745	4118	90	2490
HV284-2U*-TS	84	84	16.0	14	Two 1	235	6051	2654	4644	93	2610
HV296-2U*-TS	96	96	16.0	14	Two 1	250	6144	2447	4894	88	2720
HV2108-3U*-TS	108	108	16.0	14	Three 1	330	6000	2745	6177	90	3735
HV2120-2U*-TS	120	120	16.0	14	Two 1	275	6330	2208	5519	80	3120
HV2120-3U*-TS	120	120	16.0	14	Three 1	345	6060	2678	6693	93	3615
HV2144-3U*-TS	144	144	16.0	14	Three 1	375	6144	2447	7341	88	4080

* - Use corresponding letters in "Electrical Data" columns to complete the model numbers

Note: Data above for 1725 RPM at 60 Hz, 50 Hz is 1425 RPM with a 17% reduction in the performance data.

- The AMCA Certified Ratings Seal applies to airflow rate, average outlet velocity, outlet velocity uniformity, velocity projection and power rating at free delivery only.
- Rated data shown are only for base (unheated) units, as shown.

Features:

- ❖ 1 HP Continuous Duty TEAO Motors
- ❖ Sleek self-contained one-piece heavy gauge corrosion proof paint lock metal design
- ❖ AMCA Certified to AMCA 211 (see table above for models available)
- ❖ (4) 7/16" top and wall mounting holes provided, (2) on each end
- ❖ ETL Certified to conform to UL 507 (US) and CSA 22.2 (Canada) Standards (Indoor/Outdoor Use)
- ❖ Cabinet has sufficient strength for fastening to wall on both ends without intermediate support
- ❖ Adjustable air directional vanes with 40° sweep front to back
- ❖ Standard color is Titanium Silver
- ❖ Rust preventative electrostatic polyurethane powder coating
- ❖ 5-year parts warranty
- ❖ Freight Included (FOB Continental USA)
- ❖ Proudly Made in the USA

Note: All HV2 units, the Motor Fan Assemblies (MFA) are shipped loose to minimize freight damage

Mars Recommended Accessories (See Submittals for additional details):

- ❖ Door Limit Switches
 - 99-014, Combination mechanical switch, 250v, 1HP Max
 - 99-125, Industrial surface mounted magnetic switch (controller required)
 - ❖ Controllers
 - MCPB-†U*, Motor Control Panel, 120V control voltage († = # of Motors, * = Voltage Code)
 - MCP-TD, Adjustable time delay, 1sec-100hr (panel required)
 - MCP-24V, Low voltage control option (panel required)
 - BMS-303, BMS for monitor and control (panel required with MCP-24V)
 - Note: Dry contact provided in panel for monitoring motor. 24Vac signal provided from panel for controlling motor
 - ❖ Brackets
 - B0004, Adjustable mounting bracket set, 3 1/2" clearance
 - B0008 to B0011, Extended wall mounting bracket, 10", 16", 19" 23" clearance respectively
 - ❖ Severe Duty and Finish
 - HSG-304SS-HV/EP, 304 Stainless steel housing construction
 - INS-WD-HV2, Washdown motor fan assembly, IP54
 - INS-XP-HV2, Explosion resistant motor fan assembly, Class 1, Division 1, Group D
- Note: Washdown and explosion proof units will require higher motor amperage. Please specify at the time order for correct panel rating.

Sound Levels: (measured at 10' in an open field)

1 Motor Unit = 70 dBA, 2 Motor Unit = 73 dBA, 3 & 4 Motor Unit = 75 dBA

Model	Projection Velocity	
	Distance from nozzle (in)	Avg. Core Velocity (FPM)
HV236-1U*	40	2002
	80	1238
	120	1088
	160	1039
	200	967

Electrical Data (FLA)	Unit Voltage (Voltage Code)				
	Single Phase		Three Phase		
	115v/1Ø (A)	208-230v/1Ø (D)	208-230v/3Ø (G)	460v/3Ø (H)	575v/3Ø (I)
HV236-1U*-TS	9.0	5.0	3.3/3.2	1.6	1.3
HV242-1U*-TS	9.0	5.0	3.3/3.2	1.6	1.3
HV248-1U*-TS	9.0	5.0	3.3/3.2	1.6	1.3
HV260-1U*-TS	9.0	5.0	3.3/3.2	1.6	1.3
HV272-2U*-TS	18.0	10.0	6.6/6.4	3.2	2.6
HV284-2U*-TS	18.0	10.0	6.6/6.4	3.2	2.6
HV296-2U*-TS	18.0	10.0	6.6/6.4	3.2	2.6
HV2108-3U*-TS	27.0	15.0	9.9/9.6	4.8	3.9
HV2120-2U*-TS	18.0	10.0	6.6/6.4	3.2	2.6
HV2120-3U*-TS	27.0	15.0	9.9/9.6	4.8	3.9
HV2144-3U*-TS	27.0	15.0	9.9/9.6	4.8	3.9

* - Use corresponding letters in "Electrical Data" columns to complete the model numbers

Alternate voltage codes with FLA (Full Load Amp) data:

277v/1Ø/60Hz (L) - 5.2A per motor 380-415v/3Ø/50Hz (W) - 1.8A per motor
220v/1Ø/50Hz (U) - 7.1A per motor

For total FLA, multiply motor FLA by # of motors.

Amperage (MCA) = total FLA X 1.25

EXAMPLE

HV2 144 - 3 U H - TS

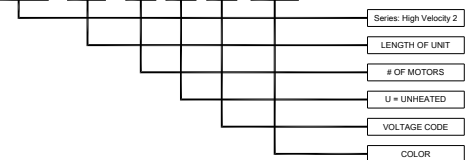

MARS Air Systems, LLC certifies that the Air Curtains shown on this data sheet are licensed to bear the AMCA seal. The ratings shown are based on tests and procedures performed in accordance with AMCA Publication 211 and comply with the requirements of the AMCA Certified Ratings Program.

The AMCA Certified Ratings Seal applies to airflow rate, average outlet velocity, outlet velocity uniformity, velocity projection and power rating at free delivery only.

NOTE: Models HV260-1, HV2108-2 & HV2120-2 are not AMCA Certified.



atmosphere is everything

14716 S. Broadway • Gardena, CA 90248 • USA
 TEL:(310) 532-1555 • (800) 421-1266 • FAX:(310) 324-3030
 Web Site: www.marsalr.com • E-mail:Info@marsalr.com

PROJECT		OPTIONS/ITEMS	
TITLE		DATE 6/6/16	
COMMENTS		PAGE	
		REV. NO 1	
MODEL NO. Series 2	DRAWING NO. TYPICAL UNHEATED	DRAWN BY BH	CHECKED BY
		FILE NAME	

TYPICAL UNHEATED DIAGRAMS

SINGLE PHASE

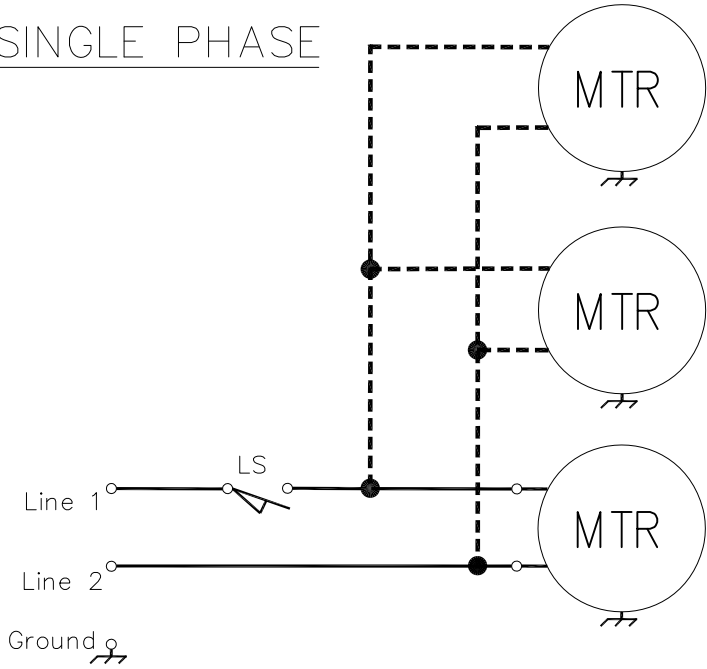

120/208-240v Single Phase Motor

1/2 H.P. Use 15A Micro Switch
 1 H.P. Use 20A Micro Switch

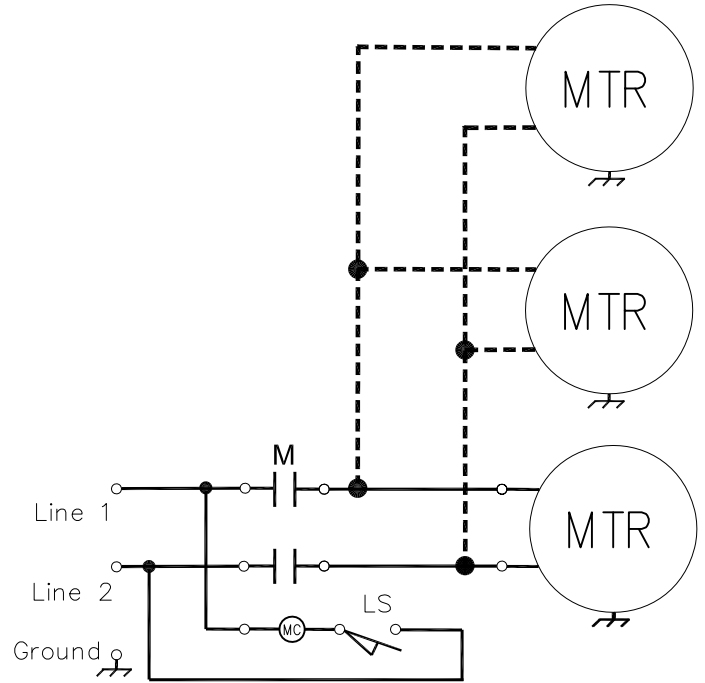

120/208-240v Single Phase Motor

Larger than 1 H.P. Use Contactor and
 15A Micro Switch

THREE PHASE

208-240/460v Three Phase Motor

All Motors Use Contactor and
 15A Micro Switch

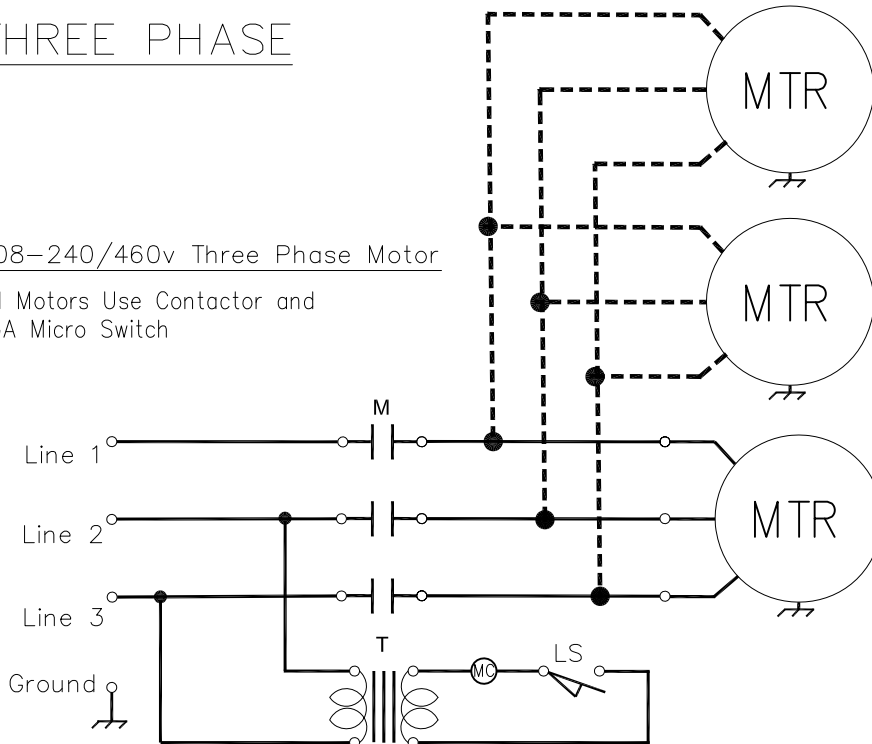

Note: This wiring diagram is applicable for:
 Single Phase motors as follows-
 LPV2: Up to 3 motors
 STD2: Up to 2 motors
 HV2: 1 motor

See *Door Limit Switch submittal for
 additional switch info

SYMBOLS

- LS - Micro Switch
- M - Contactor or Motor Starter
- MC - Contactor Coil
- T - Control Transformer

ACCESSORY INSTALLATION SUPPLEMENT

Door Limit and Magnetic Reed Switches

1. Mars door limit and magnetic reed switches are available with NEMA 1, 4X and 7 ratings. Contact the factory for additional ratings and details. (See FIG. 1 for typical single swing, hinged door type, door limit switch installation)

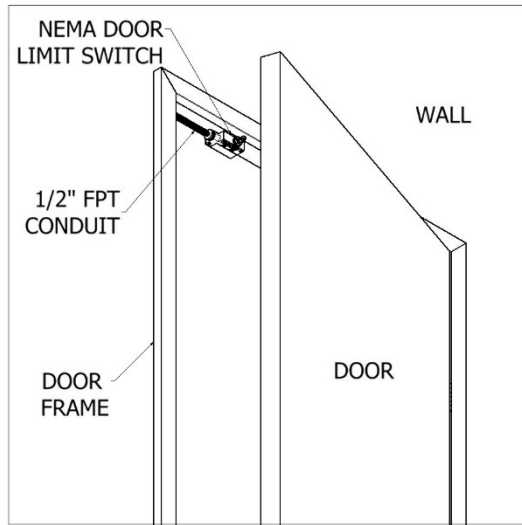

FIG. 1

2. Use light gauge materials when field fabricating brackets to activate and deactivate the door limit switch(es). (FIG. 2) Figure 2 also shows the typical installation of the combination plunger/roller type NEMA 1 door limit switch, for all non-hinged style doors.

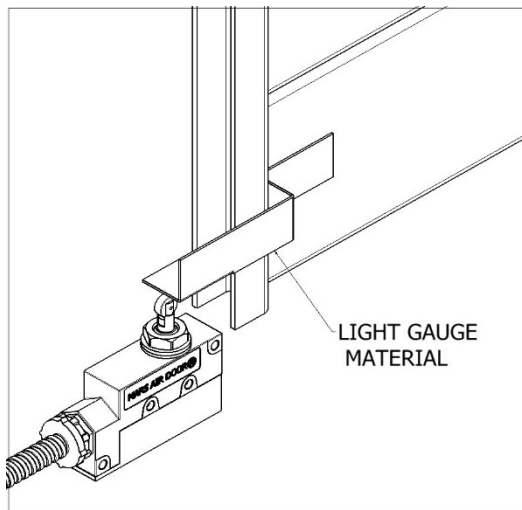

FIG. 2

3. All wiring must be per local and NEC (National Electric Code) codes.
4. Panels or controllers may be required. Refer to wiring diagram inside the control panel box.

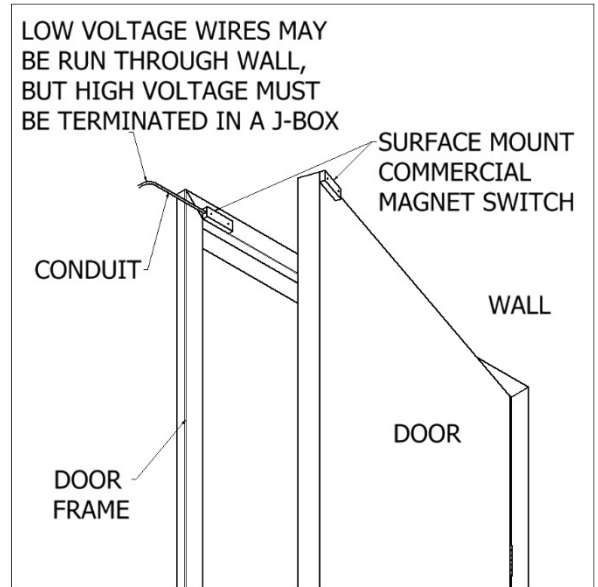

FIG. 3

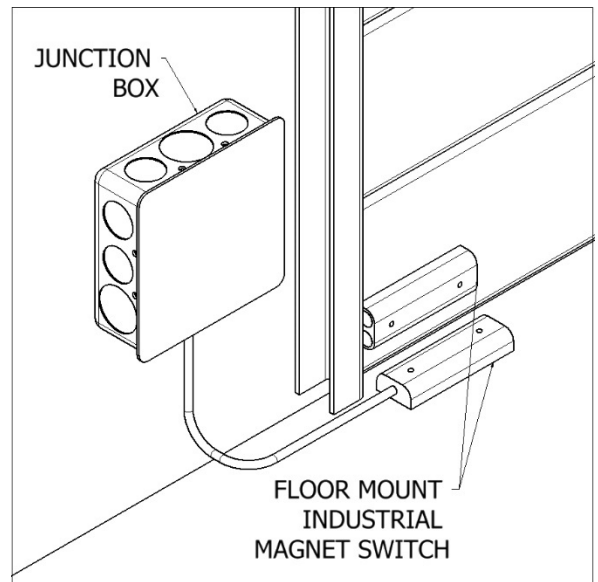

FIG. 4

atmosphere is everything

Bracket Installation

1. Side Extension Plates: For doorways wider than the air curtain, use combination of Side Extension Plates and Adjustable Mounting Brackets. (FIG. 5)

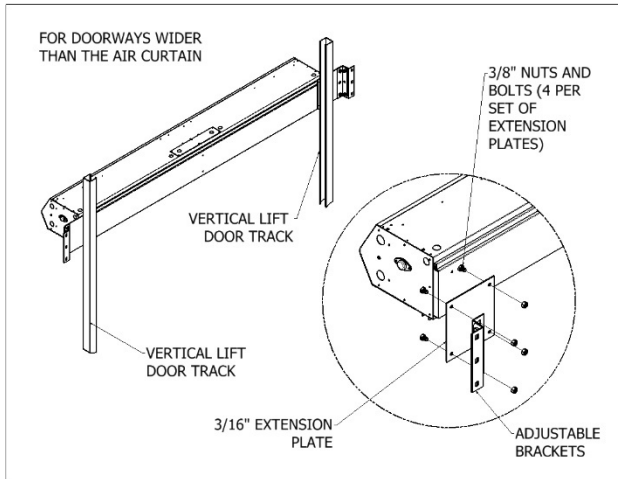

FIG. 5 (LPV SHOWN)

2. Adjustable Mounting Brackets: For installation of air curtain over drum-style roll-up door, use Extended Wall Mounting Brackets. (FIG. 6)

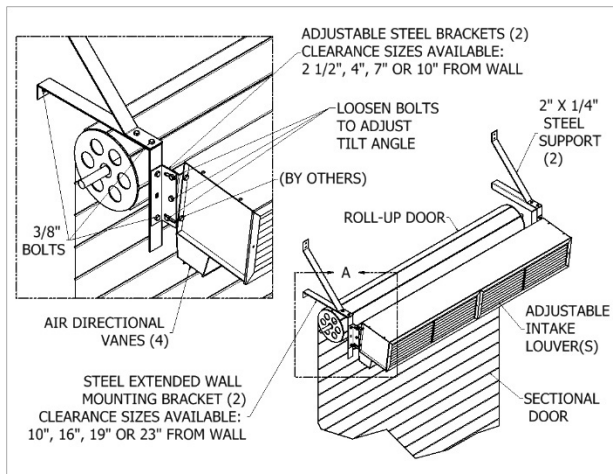

FIG. 6 (STD SHOWN)

3. Extended Wall Mounting: For Tandem Mounting of air curtain over sectional style door, use either wall mounting angle brackets or threaded rods.

4. Top Mounting Brackets: For overhead installation of units, use in conjunction with the threaded holes provided on top of unit.

Note: Angle brackets, threaded rods and I Beams are provided by others. (FIGS. 7 & 8) All optional brackets are not available for WMI/WMH and BD Series.

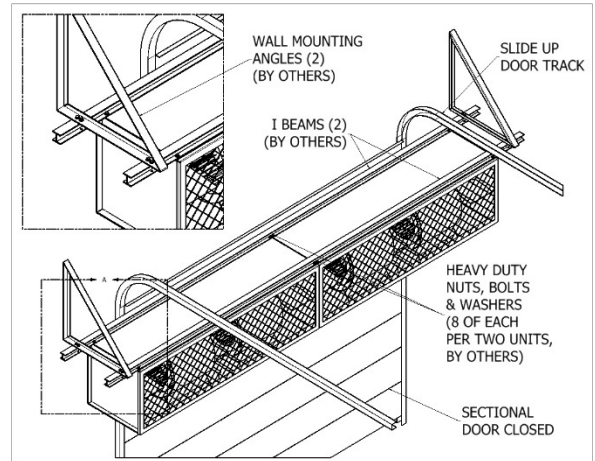

FIG. 7 (WMI/WMH SHOWN)

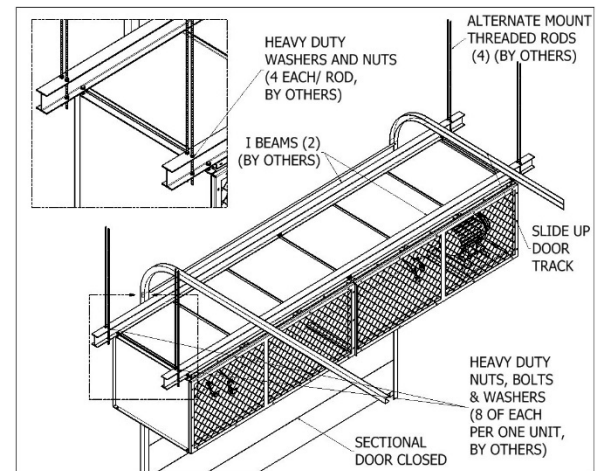

FIG. 8 (BD SHOWN)

STANDARD 2 (STD2), HIGH VELOCITY 2 (HV2), EXTRA POWER 2 (EP2) AND ETL SANITATION CERTIFIED INDUSTRIAL SERIES

Installation, Operation and Maintenance Manual

Please read and save these instructions. Read carefully before attempting to assemble, install, operate, or maintain the product described. Protect yourself and others by observing all safety information. Failure to comply with these instructions could result in personal injury and/or property damage. Retain these instructions for future reference.

OVERVIEW

Mars Air Curtains are designed to cover door openings, providing both temperature control/environmental separation and flying insect control, when the building's doors are opened. Typical installation heights are:

Standard 2 Series (Environmental Separation up to 12', Flying Insect Control up to 10'), High Velocity 2 Series (Environmental Separation up to 14', Flying Insect Control up to 12'), and Extra Power 2 Series (Environmental up to 16', Flying Insect Control up to 14'). All ETL Sanitation Certified Series should be mounted at 7' for Flying Insect Control. The units are typically wall mounted horizontally above the door opening. They can also be suspended from the ceiling or vertically mounted alongside the opening. The units are ETL Listed for either an inside or outside mount. Heated units must be mounted on the inside or the protected side of the opening. The motors used in the Standard 2, High Velocity 2 and Extra Power 2 Series are 1/2HP, 1HP and 3HP, respectively. The ETL Sanitation Series utilizes 1/2HP and 1HP motors.

The Standard 2, High Velocity 2 and Extra Power 2 Series come standard with an air intake grille. They can also be configured with an aluminum mesh air intake filter instead of the air intake grille or in conjunction with it.

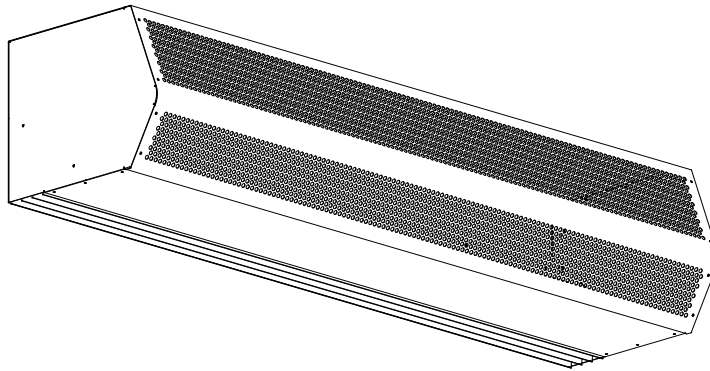

GENERAL SAFETY INFORMATION

Use this product only in the manner intended by the manufacturer. If you have any questions, contact the manufacturer. Only qualified personnel should install this product. Installing personnel should have a clear understanding of these instructions and should be

aware of general safety precautions. Improper installation can result in electric shock, possible injury due to coming in contact with moving parts, as well as other potential hazards.



WARNING

To reduce the risk of fire, electric shock, or injury to persons, observe the following.

- A. Always disconnect, lock and tag power source before installing or servicing product.
- B. Installation work or electrical wiring must be done by qualified person(s) in accordance with all applicable codes and standards, including fire-rated construction.
- C. The combustion airflow needed for safe operation of fuel burning equipment in the area may be affected by the product's operation. Follow the heating equipment manufacturer's guideline and safety standards, such as those published by the National Fire Protection Agency (NFPA), the American Society of Heating, Refrigeration and Air Conditioning Engineers (ASHRAE) and local code authorities.
- D. When cutting or drilling into a wall or ceiling, be careful not to damage electrical wiring and other hidden utilities.



WARNING

When servicing the product, motor may be hot enough to cause pain or injury. Allow motor to cool before servicing.



WARNING

Precaution should be taken in explosive atmospheres.

RECEIVING AND INSPECTION

Upon receiving the product, check to make sure all items are accounted for by referencing the Bill of Lading to ensure all items were received. Inspect each carton for shipping damage before accepting delivery. Notify the freight carrier if any damage is noticed. The carrier will make notification on the delivery receipt acknowledging any damage to the product. All damage should be noted on all copies of the Bill of Lading which is countersigned by the delivering carrier. A Carrier Inspection Report should be filled out by the carrier upon arrival and a report given to the Traffic Department. If damaged upon arrival, file a claim immediately with the carrier. Any physical damage to the unit after acceptance is not the responsibility of Mars Air Systems.

UNPACKING

Verify that all parts, components and accessories, and the correct quantities of each have been received. If any items are missing, report shortages to Mars Air Systems directly to arrange for obtaining the missing items. Again, verify quantities received against those on the Bill of Lading only, as multiple shipments may be involved.

INSTALLATION

Typical Mounting – Wall or Ceiling Mounted Horizontally Above the Door Opening

1. Remove the air intake grille(s) and/or filter(s) from the product and set aside. Only products 48" or less, except HV2 and EP2 models, are shipped with the motor fan assembly (MFA) mounted inside.
2. Measure the housing and center it over the opening. The air curtain shall be equal to or greater than the width of the opening.
3. Total of two (2) key-hole slots and six (6) pre-punched mounting holes are provided for your convenience. The 7/16" pre-punched holes (4) provided, (2) on each end for top/ceiling mounts. The 1/2" key-hole slot and 7/16" pre-punched hole (2) provided, (2) on each end for wall mounts. These holes must be utilized to secure the product to the wall or ceiling. If necessary, holes may be drilled inside the product to align with the stud spacing. All hardware is field provided by others.
4. Mount the product such that the discharge is 1" above the opening and all obstacles. (FIG. 1)

Note: If the product is installed higher than the recommended 1" above the opening, then it must be moved 3/8" away from the wall for every 1" that it is

moved up. Any void between the wall and the product must be sealed, by others, to optimize performance.

5. Use four (4) threaded rods for overhead installation or four (4) threaded bolts for wall installation. All hardware is field provided by others. (FIG. 1)
6. If applicable, optional Adjustable Mounting Brackets, Side Extension Plates and Extended Wall Mounted Brackets are also available for installations over a Vertical Lift or Drum Roll-up type door. (Reference **Accessory Installation Supplement**)
7. If applicable, for tandem installation or products mounted side by side, allow no more than 6" between the two products. For overhead installation using threaded rods, the products may require a beam, by others, to span the full distance of the mounting length. (Reference **Accessory Installation Supplement**)
8. All wires must be connected internal of the unit and some knockouts are provided. However, it may be necessary to create your own knockout, as required.
9. The unit must be wired per NEC and local codes.

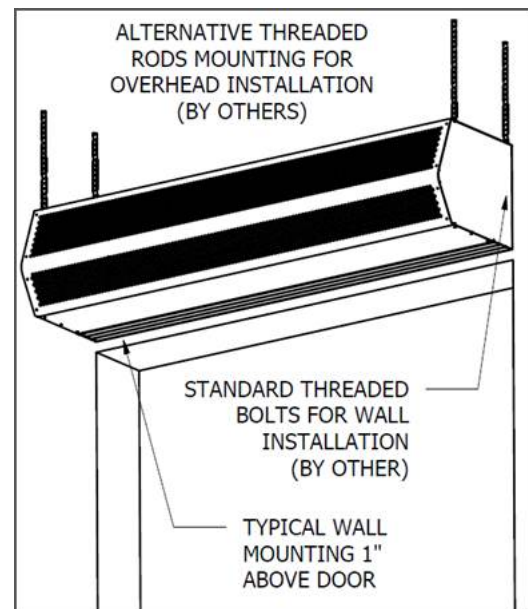

FIG. 1

Motor Fan Assembly Installation and Electrical Field Wiring

1. Once the housing is installed over the opening, the Motor Fan Assembly (MFA) must be re-placed and securely fastened. For products with the MFA shipped loose, wing nuts or hex nuts are provided inside the unit (FIG. 2). For heated MFA installation, reference **Heated Products Supplement Sheet**.
2. The unit and any optional accessories must be wired with the proper voltage to the junction box per the wiring diagram. (FIG. 3, unheated products only)
3. All 3 phase motors are bi-directional, which means they can rotate in either direction. Follow directional arrows on the blower wheel housings for proper rotation. If the motor is rotating incorrectly, switch two of the 3 phase

power or motor leads and the motor will rotate the opposite direction. Make sure all motors are turning in the same and proper direction. (FIG. 2)

4. Replace the air intake grille(s) or filter(s) once the product has been properly tested.

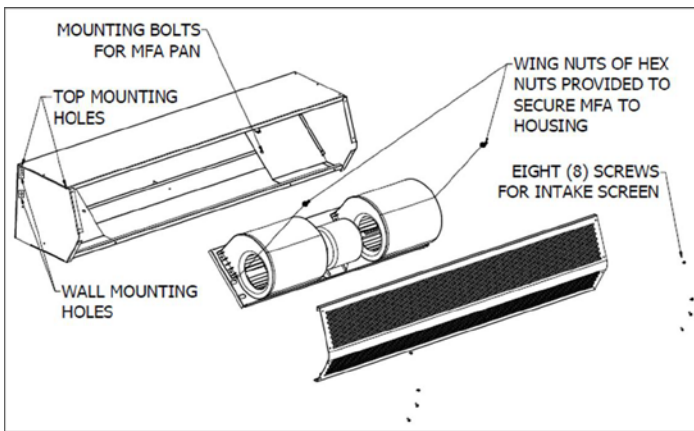
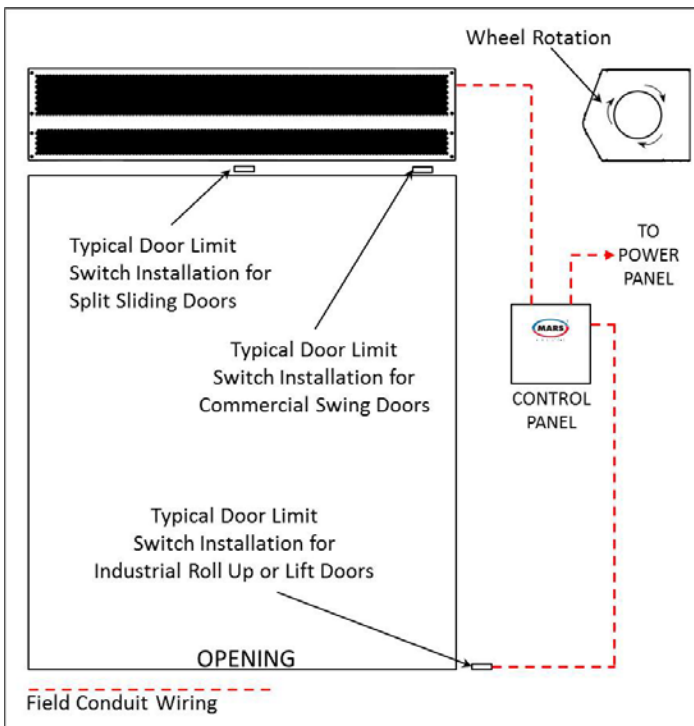

FIG. 2



NOTE

For accessory installation, reference Accessory Installation Supplement.
For heated products, reference Heated Products Supplement.

FIG. 3

START-UP

This product has been assembled and tested at the factory prior to shipping. The following procedures should be performed to assure its performance. Before continuing with the start-up, it is important to recognize the safety controls furnished with the unit.



WARNING

The following items must all be completed by a qualified installer and checked off when completed

- A. Re-check that the product has been installed properly and is level and secure.
- B. Check all terminal screws are tight and field wiring is connected in accordance to National Electrical Code and wired per the enclosed wiring diagram. For electric heated models, ensure that the coils are secured and not touching each other on any metal surface.
- C. Verify proper voltage prior to powering the product. (See product label for reference).
- D. Check all field wired components "if supplied" are wired correctly.
- E. Check that the inlet air supply and the discharge air supply are free of obstructions.
- F. Check that all air filter(s) and/or air intake grille(s) are in place and installed properly, as originally shipped.
- G. Verify voltage to the product once more and turn power on.
- H. Regardless of whether the product is mounted on the inside or outside of the door opening, set the air directional vanes in the discharge nozzle slightly outward to approximately 10-15° towards the outside, or the wind load. (FIG. 4)

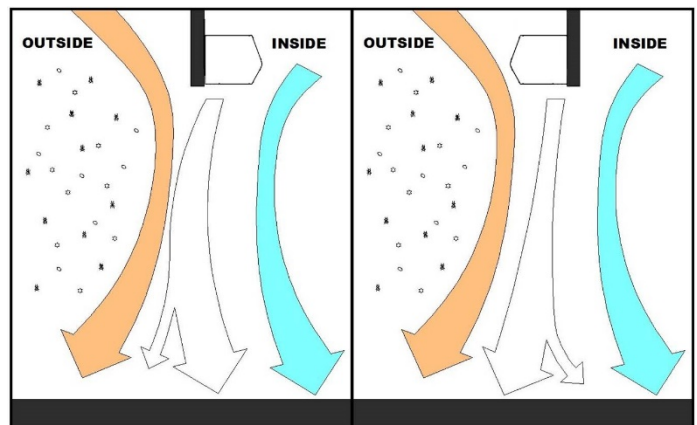

FIG. 4

- I. For products with control panels, turn the HOA (Hand-On-Auto) selector switch to "On" position and open the door to energize the product. For products without

a control panel or an On/Off switch, open the door to energize the product.

- J. If heated products are installed, reference **Heated Products Supplement**.
- K. For three phase units, verify direction of rotation of blower wheels (note direction arrows on the blower wheel housing). Correct if needed by changing polarity of three phase power.
- L. **VERY IMPORTANT** Using a clamp meter, measure the amperage to each motor and ensure that they do not exceed the amperage listed on the product label.
- M. If applicable, adjust the air intake grille(s) such that the output air stream reaches the floor. For temperature control and environmental separation applications, the air stream should reach the floor with sufficient strength to create an air seal around the door opening without creating turbulent mixing of the inside and outside air. For flying insect control applications, the air stream should reach the floor with maximum strength. If after proper installation and adjustment, the product appears to be producing too little or too much air for the application, contact the manufacturer.



WARNING

Prevent hazard of electrical shock. More than one disconnect switch may be required to de-energize this product.

MAINTENANCE



WARNING

To reduce the risk of fire, electrical shock, or injury to persons, observe the following:

- A. Maintenance is to be performed only by qualified personnel who are familiar with local codes and regulations and are experienced with this type of product.
- B. Before servicing or cleaning the product switch power off at service panel and lock service panel to prevent power from being switched "ON" accidentally.

Routine maintenance is required to keep this product operating at its peak performance and efficiency. Over time, the housing, air intake grille, air intake filter, blower wheels and motor(s) will accumulate a buildup of dust, debris and other residue. It is imperative to keep these components clean. Failure to do so will not only lower operational efficiency and performance, but also reduce the useful life of the product. The time between cleanings depends on the application, location, and daily hours of use. On average, under normal use conditions, the product should require a thorough cleaning once every six (6) months.

To clean the product, perform the following:

1. Verify the product has been disconnected from the power source.
2. Use a damp cloth and either a warm mild soapy water solution or bio-degradable degreaser, to wipe down the exterior components of the housing.
3. To access the interior of the product, remove the air intake grille and/or air intake filter. This is accomplished by removing the eight (8) self-tapping screws on the face of each air intake grille/filter.
4. Thoroughly clean the air intake grille/filter.
5. Remove the motor fan assembly (MFA) from inside the air curtain housing. This is accomplished by loosening the watertight fitting and pulling the cord out (3 phase power) or by the quick disconnect plug on the motor (1 phase power). Then remove the two (2) wing nuts on the out-board sides of the MFA pan. Care should be taken to avoid the MFA from tipping over.
6. Remove the MFA from the unit and thoroughly wipe down the motor, blower wheels and blower wheel housings. Be careful not to submerge the motor in water or spray it with a water hose.
7. The motor(s) require no additional lubrication. They are permanently lubricated and feature double sealed ball bearings.
8. To re-install the product, reverse the procedures above.
9. Reconnect the power source to the product
10. If you have any questions regarding the maintenance of the product, contact the manufacturer.

SPECIAL APPLICATIONS

Outdoor Installation

For outdoor unit special consideration may be required for enclosure, motor, wheel, and other components to minimize damage caused by exposure to the outdoor elements. Contact factory for special construction and costing.

Freezer and Cooler Installation

Air curtain must be mounted on the warm side for optimal performance. Variable Frequency Drive (VFD) is strongly recommended to control the air curtain air flow velocity at the floor level.

High humid areas may require de-humidifier or additional defrost cycle to minimize condensation and freezing for freezer applications. We recommend the air curtain unit to not replace doors but work in conjunction with door opening sequence cycle. Contact factory for details.

CAUTION

The appliance is not to be used by persons (including children) with reduced physical, sensory, or mental capabilities, or lack of experience and knowledge, unless they have been given supervision or instruction. Children are not to play with the appliance.

DISCLAIMER

Mars reserves the right to change specifications and product design without notice. Such revisions do not entitle the buyer to corresponding changes, improvements, additions, or replacements for previously purchased equipment.

TROUBLESHOOTING

PROBLEM	CAUSE	SOLUTION
NO AIR BLOWING OUT OF DISCHARGE NOZZLE	<ul style="list-style-type: none"> - No power being supplied to the unit from the electrical power source - Circuit breaker is tripped - Blown fuses on power supply - Motor overload is open or tripped - Motor contactor / relay defective (if applicable) - Failed switch 	<ul style="list-style-type: none"> - Confirm power source / check if in on position - Reset circuit breaker - Replace fuses - Allow the motor to cool down; motor has auto reset internal overload; if unit is panel equipped, press reset button on overload inside panel, or replace motor overload if overload remains tripped - Check voltage to coil; check contacts to see if they are pulling in - Replace or repair limit switch
MOTOR IS RUNNING BUT FANS ARE NOT SPINNING	<ul style="list-style-type: none"> - Loose or broken coupling (belt drive) - Loose set screws on wheel hubs - Fan spinning inside fan housing - Broken fan hub 	<ul style="list-style-type: none"> - Replace or tighten coupling - Tighten set screws on motor shaft flats - Tighten fan on shaft or replace fan - Replace fan wheels
ELECTRICAL CONTROLS NOT WORKING WHEN DOOR IS OPEN	<ul style="list-style-type: none"> - Switch is in off position - Door limit switch is not operating 	<ul style="list-style-type: none"> - Turn unit's switch to the on position - Repair or replace door limit switch
UNIT WILL NOT TURN OFF	<ul style="list-style-type: none"> - Door limit switch is permanently closed or energized 	<ul style="list-style-type: none"> - Position the door switch in a manner that turns off the unit when the door closes and turns on the unit when the door opens. Only light pressure required.
LOW AIR FLOW	<ul style="list-style-type: none"> - Discharge air vanes out of adjustment - Obstruction on intake or discharge - Power leads out of polarity - Blower motor rotating below normal speed - Fan rubbing against housing - Blower wheels clogged with dirt 	<ul style="list-style-type: none"> - Adjust vanes to proper position (Refer to Start-Up Section in this manual) - Remove obstruction or move air curtain - Switch power leads to correct polarity (3 phase models only) - Apply proper voltage per unit requiremen (see unit label) / Adjust adjustable motor speed knob (if applicable) - Free fan from housing - Clean and remove dirt from blower wheels
EXCESSIVE AIR VELOCITY AT DOOR OPENING	<ul style="list-style-type: none"> - Nozzle out of adjustment and not angled far out enough (BD only) - Air temperature too cold - Air stream pushing air outside of the building 	<ul style="list-style-type: none"> - Adjust nozzle angle to outside - Add auxiliary heat to overcome wind chill - Adjust discharge angle back into building
AIR NOT HITTING THE FLOOR	<ul style="list-style-type: none"> - Low air velocity - Obstruction in the direction of air flow - Negative building pressure 	<ul style="list-style-type: none"> - Adjust vanes to proper position or check installation height (Refer to Start-Up Section in this manual) - Remove obstruction or move air curtain (Move out 3/8" for every 1" up from the door) - Provide a make-up air system to relieve negative building pressure
UNEVEN AIR	<ul style="list-style-type: none"> - Shaft rotating inside fan - One motor not functioning 	<ul style="list-style-type: none"> - Replace fan or tighten fan on shaft - Replace or repair motor
EXCESSIVE NOISE AND OR VIBRATION	<ul style="list-style-type: none"> - Loose or broken coupling (belt drive) - Loose set screws on wheel hubs - Fan spinning inside fan housing - Broken fan hub - Bearing end caps worn - Damaged blower wheel - Bearing end caps worn - Balancing clips missing 	<ul style="list-style-type: none"> - Replace or tighten coupling - Tighten set screws on motor shaft flats - Tighten fan on shaft or replace fan - Replace fan wheels - Replace Bearing end caps - Replace Blower Wheel - Replace Bearing end caps - Replace Blower Wheel

TROUBLESHOOTING MOTOR

To determine if the motor is in good operating condition, compare measured motor resistance at the motor terminals to the values shown below.

MARS MOTOR RESTANCE READINGS										
Single Phase Motors										
 atmosphere is everything								MOTOR WIRES OR TERMINAL (T) OHM READINGS		
								HIGH SPEED (1750)	MEDIUM SPEED (1650)	LOW SPEED (1450)
Applicable Air Curtain Series	Mars Part #	Manufacturer Part #	Brand	Motor Rating	HP	Voltage	Phase	Black Motor Wire & White Motor Wire	-	-
LPV2, LPN2	03-001	7190-1682	Fasco	Nema 1	1/6	115	1	11.5	-	-
	03-002	7190-1903	Fasco	Nema 1	1/6	115	1	8.4	-	-
	03-003	7190-1825	Fasco	Nema 1	1/6	230	1	64	-	-
	03-004	7190-1904	Fasco	Nema 1	1/6	230	1	44.6	-	-
Applicable Air Curtain Series	Mars Part #	Manufacturer Part #	Brand	Motor Rating	HP	Voltage	Phase	White Motor Wire (T1) & Black Motor Wire (T3)	White Motor Wire (T1) & Black Motor Wire (T5)	White Motor Wire (T1) & Black Motor Wire (T2)
STD2, N2, PH10, QP10	03-010	34G928X169	Baldor	Washdown (IP54)	1/2	115	1	1.2	-	-
	03-010	34G928X169	Baldor	Washdown (IP54)	1/2	208/230	1	4.6	-	-
	03-005	7124-1175	Genteq	Nema 1	1/2	115	1	2.6	3.8	5.2
	03-006	7124-1560	Genteq	Nema 1	1/2	208/230	1	9.9	15.9	22.5
	03-007	48S17T439	Marathon	Nema 1	1/2	277	1	7.7	-	-
	03-005	K055PWM1736C13H	Nidec	Nema 1	1/2	115	1	2.1	3.7	5.2
	03-005	K055PWM1736C13H	US	Nema 1	1/2	115	1	5.3	3.7	5.4
03-006		US	Nema 1	1/2	208/230	1	8.7	18.2	24.2	
Applicable Air Curtain Series	Mars Part #	Manufacturer Part #	Brand	Motor Rating	HP	Voltage	Phase	White Motor Wire (T1) & Black Motor Wire (T2)	White Motor Wire (T1) & Black Motor Wire (T3)	-
HV2, NH2, PH12	03-021	35T276R025G1	Baldor	Washdown (IP54)	1	115	1	0.7	-	-
	03-015-Baldor	35M316S174	Baldor	Nema 1	1	115	1	0.6	-	-
	03-015-Baldor	35M316S174	Baldor	Nema 1	1	208/230	1	2.2	-	-
	03-021	35T276R025G1	Baldor	Washdown (IP54)	1	208/230	1	2.8	-	-
	03-014	7124-0985	Genteq	Nema 1	1	115	1	1.6	2.4	-
	03-015	7124-1096	Genteq	Nema 1	1	208/230	1	6.5	9.2	-
	03-015	-	Nidec	Nema 1	1	208/230	1	4.3	6.5	-
	03-014	K55BWJZB-2362	US	Nema 1	1	115	1	1	2.1	-
03-015	-	US	Nema 1	1	208/230	1	3.2	6.3	-	
Three Phase Motors										
Applicable Air Curtain Series	Mars Part #	Manufacturer Part #	Brand	Motor Rating	HP	Voltage	Phase	LEAD WIRE OHM READINGS		
								Black Motor Wire (L1) & Red Motor Wire (L2)	Black Motor Wire (L1) & White Motor Wire (L3)	Red Motor Wire (L2) & White Motor Wire (L3)
STD2, N2, PH10, QP10	03-008	P55YDHB-1527	US	Nema 1	1/2	208-230	3	16.1	16.1	16.1
	03-008	P55YDHB-1527	US	Nema 1	1/2	460	3	63.6	63.6	63.6
	03-009	48T17T135	Marathon	Nema 1	1/2	575	3	136	136	136
HV2, NH2, PH12	03-017	56T17T5541	Marathon	Nema 1	1	208-230	3	4.3	4.3	4.3
	03-017	56T17T5541	Marathon	Nema 1	1	460	3	16.5	16.5	16.5
	03-018	56T17T5544	Marathon	Nema 1	1	575	3	26.6	26.6	26.6
	03-022	35N127S902	Baldor	Washdown (IP54)	1	208-230	3	5.1	5.1	5.1
03-022	35N127S902	Baldor	Washdown (IP54)	1	460	3	19.8	19.8	19.8	
EP2	03-026	165716	Century	Nema 1	3	208-230	3	1.5	1.5	1.5
	03-026	165716	Century	Nema 1	3	460	3	5.7	5.7	5.7
	03-028	35E92Y26	Baldor	Nema 1	3	575	3	9.2	9.2	9.2
WMI	03-110	36H110-2211G1	Baldor	Nema 1	1,2,3	208-230	3	3.5	3.5	3.5
	03-110	36H110-2211G1	Baldor	Nema 1	1,2,3	460	3	13.5	13.5	13.5
WMH	03-055	37F932W828G1	Baldor	Nema 1	5	230	3	0.7	0.7	0.7
	03-055	37F932W828G1	Baldor	Nema 1	5	460	3	2.4	2.4	2.4
	03-046	37F909X889G1	Baldor	Nema 1	7	230	3	0.6	0.6	0.6
	03-046	37F909X889G1	Baldor	Nema 1	7	460	3	1.6	1.6	1.6
BD	03-033	U639A - 215TFC6027	Marathon	Nema 1	10	208-230	3	0.4	0.4	0.4
	03-033	U639A - 215TFC6027	Marathon	Nema 1	10	460	3	1.2	1.2	1.2
	03-074	GT1128A 170118.60	Marathon	Nema 1	25	575	3	0.5	0.5	0.5

WARRANTY

Mars' warranty coverage, period, extent, and limitations apply to the product only. It does not apply to labor. Mars warrants that Mars product 1) Is free from defects in materials and workmanship and 2) Conforms to Mars' published specifications. The warranty period for Mars product except heated and custom models, is a five (5) year period commencing on its date of shipment. The date on customer's invoice is the date of shipment unless Mars or your reseller informs you and Mars otherwise. For heated products, the warranty period is an eighteen (18) month period and for custom products and accessories, the warranty period is twelve (12) months period commencing the date of shipment. Mars will provide free replacement of any part that fails as a result of a defect in material or manufacturer's workmanship. Changes in operational specification parameters that are different from those provided on the original purchase order are not covered. Mars product is inspected and tested before packaging and is shipped in working condition. The warranty for Mars product only covers free-of-charge replacement of failed parts. The warranty does not cover labor and transportation expenses that may be required to provide and to install replacement parts. Because in many instances, it is impossible to determine the cause of failure, customer may be responsible for transportation charges associated with replacement of failed part. Mars does not warrant uninterrupted or error-free operation of Mars product. Under no circumstance is Mars liable for any of the following: 1) Third-party claims against you for damages; or 2) Special, incidental, or indirect damages or for any economic consequential damages (including lost profits and savings), even if Mars, its suppliers, or its reseller is informed of their possibility. The warranty does not cover repair or exchange of Mars product resulting from misuse, accident, modification, unsuitable physical or operating environment, improper maintenance and installation by customer, or failure caused by a product for which Mars is not responsible. The warranty does not cover damages caused by mishandling during transportation. The warranty is voided by removal or alteration of Mars product or parts identification labels, by improper installation of product, and resulting non-compliance to federal, state, and local codes and regulations. Additionally, Mars reserves the right to void the warranty for non-payment of invoice.

CONTACT FACTORY FOR COMPLETE PARTS LIST FOR ALL MODELS.

KEEP THIS MANUAL FOR YOUR RECORDS.

Model Number: _____

Serial Number: _____

Date Purchased: _____

Dealer Purchased From: _____



atmosphere is everything

14716 S. Broadway St., Gardena, CA 90248

(310) 532-1555 • (800) 421-1266

Fax: (310) 324-3030

Please go to our website at www.marsair.com for a downloadable version of this document.



atmosphere is everything

SECTION 23 34 33

AIR CURTAINS

Important Note: This specification contains hidden text appearing in red. To show or remove hidden text in MSWord, click the "File" tab or "Office" icon on the top-left corner, select "Options," select "Display," and check or uncheck the box marked "Hidden Text."

PART 1 GENERAL

1.1 SECTION INCLUDES

- A. Air curtains for pedestrian entrances.
- B. Air curtains for vehicular entrances.
- C. Air curtains for large loading dock doors.

1.2 RELATED SECTIONS

- A. Section 05 50 00 – Metal Fabrications: Concealed steel support members.
- B. Section 06 10 00 – Rough Carpentry.
- C. Section 05 41 00 – Structural Metal Studs.
- D. Section 07 62 00 – Sheet metal flashing.
- E. Section 07 92 00 – Joint Sealants.
- F. Section 08 10 00 – Metal Doors and Frames.
- G. Section 08 33 00 – Overhead Coiling Doors.
- H. Section 08 42 00 – Entrance Doors.
- I. Section 22 10 00 – Plumbing Piping:
- J. Section 23 21 00 – Hydronic Piping: Hot water heating piping to units.

- K. Section 23 22 13- Steam and Condensate Piping: Steam heating piping to units.
- L. Section 26 05 00 – Equipment Wiring: Connections to building power distribution.

1.3 REFERENCES

- A. ASTM A240 / A240M -10 – Standard Specification for Chromium and Chromium.
- B. ASTM A591 / A591M -98 – Standard Specification for Steel Sheet, Electrolytic Zinc-Coated, for Light Coating Weight (Mass) Application (Withdrawn in 2005, replaced by A879/A879M).
- C. ASTM A879 / A879M -06 – Standard Specification for Steel Sheet, Zinc Coated by the Electrolytic Process for Application Requiring Designation of the Coating Mass on Each Surface.
- D. ASTM A653 / A653M -09a – Standard Specification for Steel Sheet, Zinc Coated (Galvanized) or Zinc-Iron Alloy-Coated (Galvannealed) by the Hot-Dip Process.
- E. AHRI 410-2001 – Standard for Forced-Circulation Air-cooling and Air-Heating Coils.
- F. NSF/ANSI 37 – Air Curtains for entranceways in food and food service establishments – ETL Sanitation.
- G. CRN – Canadian Registration Number Coil.
- H. ANSI Z223-NFPA 54 – National Fuel Gas Code/
- I. NEC – National Electric Code.

1.4 SUBMITTALS

- A. Submit under provisions of Section 01 33 00.
- B. Product Data: Manufacturer's data sheets on each product to be used, including:
 - 1. Preparation instructions and recommendations.
 - 2. Storage and handling requirements and recommendations.
 - 3. Installation methods.
- C. Shop Drawings: Include plans, elevations, sections, and details, indicating dimensions, tolerances, materials, fasteners, hardware, finish, piping, electrical wiring diagrams, options, and accessories.
- D. LEED Submittals: Provide documentation of how the requirements of Credit will be met:
 - 1. List of proposed materials with recycled content. Indicate post-consumer recycled content and pre-consumer recycled content for each product having recycled content.

2. Product data and certification letter indicating percentages by weight of post-consumer and pre-consumer recycled content for products having recycled content.
- E. Selection Samples: For each finish product specified, two complete sets of color chips representing manufacturer's full range of available colors and patterns.
- F. Verification Samples: For each finish product specified, two samples, minimum size 6.25 inches (160 mm) square, representing actual product, color, and patterns.
- G. Manufacturer's Certificates: Certify products meet or exceed specified requirements.
- H. Operation and Maintenance Manual: Submit manufacturer's operation and maintenance manual, including operation, maintenance, adjustment, and cleaning instructions, troubleshooting guide, parts list, and electrical wiring diagrams.

1.5 QUALITY ASSURANCE

- A. Manufacturer Qualifications: Minimum ten years documented experience producing the products specified in this Section
- B. Installer Qualifications: Minimum five years documented experience installing products specified in this Section

1.6 DELIVERY, STORAGE, AND HANDLING

- A. Store products in manufacturer's unopened packaging until ready for installation.
- B. Store in a dry, heated storage area until installation of products.
- C. Protect materials and finish from damage during handling and installation.

1.7 SEQUENCING

- A. Ensure that locating templates and other information required for installation of products of this section are furnished to affected trades in time to prevent interruption of construction progress.
- B. Coordinate the installation of wiring and control switches for air curtains with the openings and the hardware provided for such openings.
- C. Install after doors, walls, ceilings, and other adjacent surfaces are finished and painted.

1.8 WARRANTY

- A. Standard five-year limited parts warranty for unheated units against defects in workmanship and material.

- B. Standard 18-month limited parts warranty for heated units against defects in workmanship and materials.

PART 2 PRODUCTS

2.1 MANUFACTURER

- A. Acceptable Manufacturer: Mars Air Systems, LLC; 14716 South Broadway St., Gardena, CA 90248. Tel: (310) 532-1555 or (800) 421-1266. Fax: (310) 324-3030. Email: info@marsair.com. Web: www.marsair.com.
- B. Delete one of the following two paragraphs: coordinate with requirements of Division 1 section on product options and substitutions.
- C. Requests for substitutions will be considered in accordance with provisions of Section 01 33 00.

2.2 AIR CURTAIN ASSEMBLIES

- A. Motor Fan Assembly: Design for easy removal, assembly, repair, and maintenance.
 - 1. Motor: Totally enclosed air over (TEAO) cooled motor with sealed lifetime pre-lubricated ball bearings, motor starter and thermal overload protection.
 - a. Wired for single speed operation.
 - b. Wired for two speed operation.
 - c. Provide wash down type motors, NEC IP-54 for the locations indicated.
 - d. Provide explosion proof type motors, NEC Class 1, Division 1, Group D for the locations indicated.
 - e. Electrical Characteristics: 115V AC, single phase; 9.0 Amp full load per motor/fan.
 - f. Electrical Characteristics: 208/230V AC, single phase; 5.0 Amp full load per motor/fan.
 - g. Electrical Characteristics: 208/230V AC, three-phase; 3.3/3.2 Amp full load per motor/fan.
 - h. Electrical Characteristics: 460V AC, three-phase; 1.6 Amp full load per motor/fan.
 - i. Electrical Characteristics: 575V AC, three-phase; 1.3 Amp full load per motor/fan.
 - j. Meets NEC. ETL Listed to conform to UL 507 (US) and CSA22.2 (Canada) Standards. AMCA 211 Certified.
 - 2. Fans: Forward curved centrifugal type, double width, and double inlet design, directly driven to an electric motor.
 - a. Provide resilient isolation dampening mountings between motor frame and motor mounting pan
 - b. Factory balanced blower wheel assembly statically and dynamically.
- B. Housing: Self-contained one-piece type with sufficient strength for mounting from pre-punched mounting holes at both ends to adjacent walls or ceiling without intermediate support.

1. Size:
 - a. Unheated: 15-5/8 inches deep by 14 inches high (including discharge nozzle) by width of unit.
 - b. Electric Heated: 21-3/8 inches deep by 14 inches high (including discharge nozzle) by width of unit.
 - c. Hot Water/Steam Heated: 21-3/8 inches deep by 14 inches high (including discharge nozzle) by width of unit plus 10 inches for manifolds.
 - d. Indirect Fired Gas Heated: 68 1/8 inches deep by 34 inches high (including discharge nozzle) by width of unit.
 2. Mounting:
 - a. Unheated Inside Mount.
 - b. Heated Inside Mount.
 - c. Unheated Outside Mount.
 - d. Mount Location Indicated.
 3. Material:
 - a. Provide 18- and 20-gauge electro or hot dipped galvanized steel sheet housing conforming to ASTM A 591 and/or ASTM A 653.
 - b. Provide type 304 stainless steel housing with brushed finish. ASTM A 240/A 240M.
 4. Air Inlet Grille and/or Filters: Provide air inlet grille and/or filters specified.
 5. Discharge: Provide integral discharge nozzle specified.
 6. Finish and Color: Provide with, no VOC, corrosion resistant polyurethane powder coated finish for sheet metal housings.
 - a. Titanium Silver
 - b. Obsidian Black.
 - c. Pearl White.
 - d. Stainless Steel.
- C. Environmental Air Curtains: Models for Heights up to 14 feet (4267 mm) for Environmental Separation and Temperature Control and up to 12 feet (3656 mm) for Flying Insect Control.
1. Discharge Nozzle: Adjustable air foil vanes with a plus/minus 40-degree sweep front to back.
 2. Air Velocity at Nozzle:
 - a. HV236-1: 36 Inch (915 mm) Wide Units: 2745 feet/min (13.9 m/s) single 1HP motor/fan assembly.
 - b. HV242-1: 42 Inch (1065 mm) Wide Units: 2654 feet/min (13.5 m/s) single 1HP motor/fan assembly.
 - c. HV248-1: 48 Inch (1220 mm) Wide Units: 2447 feet/min (12.4 m/s) single 1HP motor/fan assembly.
 - d. HV260-1: 60 Inch (1524 mm) Wide Units: 2208 feet/min (11.2 m/s) single 1HP motor/fan assembly.
 - e. HV272-2: 72 Inch (1830 mm) Wide Units: 2745 feet/min (13.9 m/s) two 1HP motor/fan assemblies.
 - f. HV284-2: 84 Inch (2133 mm) Wide Units: 2654 feet/min (13.5 m/s) two 1HP motor/fan assemblies.

- g. HV296-2: 96 Inch (2440 mm) Wide Units: 2447 feet/min (12.4 m/s) two 1HP motor/fan assemblies.
 - h. HV2108-3: 108 Inch (2743 mm) Wide Units: 2745 feet/min (13.9 m/s) two 1HP motor/fan assemblies.
 - i. HV2120-2: 120 Inch (3050 mm) Wide Units: 2208 feet/min (11.2 m/s) two 1HP motor/fan assemblies.
 - j. HV2120-3: 120 Inch (3050 mm) Wide Units: 2678 feet/min (13.6 m/s) three 1HP motor/fan assemblies.
 - k. HV2144-3: 144 Inch (3660 mm) Wide Units: 2447 feet/min (12.4 m/s) three 1HP motor/fan assemblies.
3. Air Inlet Grille and Filters:
- a. Location: Front.
 - b. Type: Fixed air intake grille.
 - 1) Filter: Aluminum mesh, 1/4 inch (6.4 mm), washable.
 - c. Type: Filter Only as follows:
 - 1) Filter: Flat bank 1-inch, disposable.
 - 2) Filter: Flat bank 2-inch, disposable.
 - 3) Filter: Aluminum mesh, 1/4 inch (6.4 mm), washable.
 - d. Speed: 4000 cu ft/min (1888 L/s), minimum, per motor/fan assembly.
4. Sound Pressure Level At 10 feet (3 m) From Nozzle:
- a. Single Motor/Fan Units: 70 dBA.
 - b. Two Motor/Fan Units: 73 dBA.
 - c. Three Motor/Fan Units: 75 dBA.
 - d. Four Motor/Fan Units: 75 dBA.
- D. Insect Control Air Curtains: Models for Service Entry Heights to 7 feet (2134 mm) certified to NSF/ANSI Standard 37.
- 1. Discharge Nozzle: Wedge-shaped discharge outlet nozzle with adjustable air foil vanes with a plus/minus 40-degree sweep front to back.
 - 2. Air Velocity at Nozzle:
 - a. NH236-1: 36 Inch (915 mm) Wide Units: 2745 feet/min (13.9 m/s) single 1HP motor/fan assembly.
 - b. NH242-1: 42 Inch (1065 mm) Wide Units: 2654 feet/min (13.5 m/s) single 1HP motor/fan assembly.
 - c. NH248-1: 48 Inch (1220 mm) Wide Units: 2447 feet/min (12.4 m/s) single 1HP motor/fan assembly.
 - d. NH260-1: 60 Inch (1524 mm) Wide Units: 2208 feet/min (11.2 m/s) single 1HP motor/fan assembly.
 - e. NH272-2: 72 Inch (1830 mm) Wide Units: 2745 feet/min (13.9 m/s) single 1HP motor/fan assembly.
 - f. NH284-2: 84 Inch (2133 mm) Wide Units: 2654 feet/min (13.5 m/s) single 1HP motor/fan assembly.
 - g. NH296-2: 96 Inch (2440 mm) Wide Units: 2447 feet/min (12.4 m/s) single 1HP motor/fan assembly.
 - h. NH2108-3: 108 Inch (2743 mm) Wide Units: 2745 feet/min (13.9 m/s) single 1HP motor/fan assembly.
 - i. NH2120-2: 120 Inch (3050 mm) Wide Units: 2208 feet/min (11.2 m/s) single 1HP motor/fan assembly.

- j. NH2120-3: 120 Inch (3050 mm) Wide Units: 2678 feet/min (13.6 m/s) single 1HP motor/fan assembly.
- k. NH2144-3: 14 Inch (3660 mm) Wide Units: 2447 feet/min (12.4 m/s) single 1HP motor/fan assembly,
- 3. Air Speed at Floor:
 - a. Service entry doors require a minimum of 1600 fpm (8.13 m/s) at 3 feet (914 mm) from floor.
- 4. Air Inlet Grille and Filters:
 - a. Location: Front.
 - b. Speed: 4000 cu ft/min (1888 L/s), minimum, per motor/fan assembly.
 - c. Type: Fixed air intake grille.
- 5. Sound Pressure Level At 10 feet (3 m) From Nozzle:
 - a. Single Motor/Fan Units: 70 dBA.

2.3 COMPONENTS

- A. Electric Heaters: Provide complete with motor control panel factory mounted to air curtain housing, and thermostat to be field installed.
 - 1. Temperature limit controller.
 - 2. Thermostat: Wall-mounted, 24-Volt operation, with heater on/off selection.
 - 3. Heating Coils: Electrical components UL/CUL listed.
- B. Steam Heaters: Provide finned tube steam coils for field mounting on air intake side of the air curtain cabinet with opposite end connections.
 - 1. Output: Air curtain manufacturer's standard, one-row coils.
 - 2. Output: Air curtain manufacturer's standard, two-row coils.
 - 3. Coils: Certified in accordance with AHRI 410.
 - 4. Connections: Opposite end.
 - 5. Connections: Same end, right hand.
 - 6. Connections: Same end, left hand.
 - 7. Casing: One-piece unpainted galvanized steel, bolted to air curtain housing.
 - 8. Supply and return fittings on ends of casing.
 - 9. Steam Distributing coil required for 8 feet and above for same end coils. Dual supply, Single returns.
 - 10. Thermostat: Wall-mounted, 110-Volt operation, with heater on/off selection.
 - 11. Thermostat: Wall-mounted, 208/230-Volt operation, with heater on/off selection.
- C. Hot Water Heaters: Provide finned tube water coils for field mounting on air intake side of the air curtain cabinet with opposite end connections.
 - 1. Output: Air curtain manufacturer's standard, one-row coils.
 - 2. Output: Air curtain manufacturer's standard, two-row coils.
 - 3. Coils: Certified in accordance with AHRI 410.
 - 4. Connections: Opposite end.
 - 5. Connections: Same end, right hand.
 - 6. Connections: Same end, left hand.
 - 7. Casing: One-piece unpainted galvanized steel, bolted to air curtain housing.
 - 8. Supply and return fittings on ends of casing.
 - 9. Thermostat: Wall-mounted, 110-Volt operation, with heater on/off selection.
 - 10. Thermostat: Wall-mounted, 208/230-Volt operation, with heater on/off selection.

- D. Gas Heaters: Provide field mounted indirect natural gas fired, power vented duct furnace, with aluminized steel heat exchanger and die-formed stainless steel insert burners; manifolds, orifices, flame sensor, and igniter easily removable as an assembly.
1. Output: Air curtain manufacturer's standard.
 2. Complies with:
 - a. Canadian Standards Association (CSA) labeled for US and Canadian application.
 - b. ANSI Z223/NFPA 54 National Fuel Gas Code.
 - c. CAN/CGA B149.1 Installation Codes for Natural Gas Burning Appliances and Equipment.
 3. Fuel Type: Provide orifices for:
 - a. Natural gas.
 - b. LP.
 4. 24 V control voltage transformer.
 5. Combination single-stage gas control system with regulated combination redundant gas valve and intermittent spark pilot with electronic flame supervision.
 6. Optional 2 stage.
 7. Optional Modulation Gas.
 8. Limit and safety controls.
 9. Thermostat: Wall-mounted, 24-Volt operation, with heater on/off selection.
- E. Motor Control Panels for Unheated Units: Recommended for all three-phase units and single-phase units with combined motor capacities of more than 1 HP whenever a door limit switch is used to automatically start and stop the air curtain. Provide motor control panels as follows:
1. Mounting: Shipped loose to be field mounted.
 2. Mounting: Factory mounted on right hand side of air curtain housing.
 3. Mounting: Factory mounted on left hand side of air curtain housing.
 4. Electrical components UL/CUL listed.
 - a. Remote Mounted High Resolution 5" Color LCD Display with Capacitive Touch technology
 - b. Fully programmable controller
 - c. Pre-set and fully customizable programs
 - d. Time delay (Passive & Adaptive)
 - e. 24/7 timer
 - f. Maintenance schedule alerts
 - g. Status display showing date, time, temperature, and air curtain mode
 - h. Multi-unit control capability
 - i. English (IP) or Metric (SI) display readings
 - j. Password protected
 - k. Auto Lock display
 - l. Emergency shut-off button
 - m. Low voltage control signal for door activation
 - n. Integrated BMS controls
 - o. VFD compatible with 0-10VDC output
 - p. Optional BACnet option

6. Optional adaptive fan speed control based on existing field conditions. Field mounted outdoor temperature sensors required.
- F. Motor Control Panels for Electric Heated Units: Recommended for all three-phase units and single-phase units with combined motor capacities of more than 1HP whenever a door limit switch is used to automatically start and stop the air curtain. Motor Control Panel is included for all electric heated units. Thermostat is provided for field installation. Provide motor control panels as follows:
1. Mounting: Factory mounted on the inside of air curtain housing.
 2. Mounting: Factory mounted on right hand side of air curtain housing
 3. Mounting: Factory mounted on left hand side of air curtain housing.
 4. Electrical components UL/CUL listed.
 5. Electrical components UL/CUL listed.
 6. Optional Digital Programmable Controller:
 - a. Remote Mounted High Resolution 5” Color LCD Display with Capacitive Touch technology
 - b. Fully programmable controller
 - c. Pre-set and fully customizable programs
 - d. Time delay (Passive & Adaptive)
 - e. 24/7 timer
 - f. Maintenance schedule alerts
 - g. Status display showing date, time, temperature, and air curtain mode
 - h. Multi-unit control capability
 - i. English (IP) or Metric (SI) display readings
 - j. Password protected
 - k. Auto Lock display
 - l. Emergency shut-off button
 - m. Low voltage control signal for door activation
 - n. Integrated BMS controls
 - o. VFD compatible with 0-10VDC output
 - p. Optional BACnet option
 7. Optional adaptive fan speed control based on existing field conditions. Field mounted outdoor temperature sensors required.
- G. Motor Control Panels for Hot Water, Steam and Gas Heated Units: Recommended for all three-phase units and single phase units with combined motor capacities of more than 1HP whenever a door limit switch is used to automatically start and stop the air curtain. Provide motor control panels as follows:
1. Mounting: Shipped loose to be field mounted.
 2. Mounting: Factory mounted on right hand side of air curtain housing.
 3. Mounting: Factory mounted on left hand side of air curtain housing.
 4. Provide with remote mount thermostat for field installation.
 5. Electrical components UL/CUL listed.
 6. Electrical components UL/CUL listed.
 7. Optional Digital Programmable Controller:
 - a. Remote Mounted High Resolution 5” Color LCD Display with Capacitive Touch technology
 - b. Fully programmable controller

- c. Pre-set and fully customizable programs
 - d. Time delay (Passive & Adaptive)
 - e. 24/7 timer
 - f. Maintenance schedule alerts
 - g. Status display showing date, time, temperature, and air curtain mode
 - h. Multi-unit control capability
 - i. English (IP) or Metric (SI) display readings
 - j. Password protected
 - k. Auto Lock display
 - l. Emergency shut-off button
 - m. Low voltage control signal for door activation
 - n. Integrated BMS controls
 - o. VFD compatible with 0-10VDC output
 - p. Optional BACnet option
8. Optional adaptive fan speed control based on existing field conditions. Field mounted outdoor temperature sensors required.
- H. Motor Control Panels for Gas Heated Units: Recommended for all units whenever a door limit switch is used to automatically start and stop the air curtain. Thermostat is included with optional motor control panel for field installation. Provide motor control panel as follows:
1. Control Panel: Includes increased transformer for power venter(s) with integrated 24-Volt thermostat with furnace and motor controls.
 2. Thermostat: Wall-mounted, 24-Volt operation, with heater on/off selection
 3. Mounting: Factory mounted on right hand side of air curtain housing.
 4. Mounting: Factory mounted on left hand side of air curtain housing.
 5. Motor Control Panels are UL Listed and CSA Approved
 6. Electrical components UL/CUL listed.
 7. Optional Digital Programmable Controller:
 - a. Remote Mounted High Resolution 5" Color LCD Display with Capacitive Touch technology
 - b. Fully programmable controller
 - c. Pre-set and fully customizable programs
 - d. Time delay (Passive & Adaptive)
 - e. 24/7 timer
 - f. Maintenance schedule alerts
 - g. Status display showing date, time, temperature and air curtain mode
 - h. Multi-unit control capability
 - i. English (IP) or Metric (SI) display readings
 - j. Password protected
 - k. Auto Lock display
 - l. Emergency shut-off button
 - m. Low voltage control signal for door activation
 - n. Integrated BMS controls
 - o. VFD compatible with 0-10VDC output
 - p. Optional BACnet option
 8. Optional adaptive fan speed control based on existing field conditions. Field mounted outdoor temperature sensors required.

- I. Door-Activated Limit switch(s): Provide, field installed 250-Volts, 20 amps limit switch to control air curtain(s) as follows; Automatic on/off control, activates air curtain when door is opened and turns off when door is closed. Provide limit switch for direct control one 1 HP or up to two 1/2 HP single phase motors without a separate control panel. Provide a separate control panel for three-phase motors and/or units exceeding 1 HP, 250-Volts or 20 amps controlled by a limit switch.
 - 1. Type: Combination plunger/roller switch for swing and sliding doors.
 - a. Provide limit switches with NEMA 1 (20 amps) ratings in locations indicated.
 - b. Provide limit switches with NEMA 4X (10 amps) ratings in locations indicated.
 - c. Provide limit switches with NEMA 4X (15 amps) ratings in locations indicated.
 - d. Provide limit switches with NEMA 7 (10 amps) ratings in locations indicated.
 - 2. Operation for Unheated Units: Automatic on/off control, on when door is opened, off when door is closed.
 - 3. Operation for Gas Heated Units: Automatic on when door is opened, off after time delay period (60 seconds) after door is closed.
- J. Provide mounting hardware as required for the opening.

PART 3 EXECUTION

3.1 EXAMINATION

- A. Verify that required utilities are in correct location and are of correct capacities for specified products.
- B. Verify openings to receive air curtains are plumb, level, square, accurately aligned, correctly located, and in tolerance.
- C. Examine surfaces to receive air curtains. If surface preparation is the responsibility of another installer, notify Architect of unsatisfactory preparation before proceeding.

3.2 INSTALLATION

- A. Install air curtains in accordance with approved shop drawings and manufacturer's printed installation instructions.
- B. Install air curtains plumb, level, square, true to line, and weathertight, without warp or rack.
- C. Anchor air curtains securely in place to supports.
- D. Coordinate with sheet metal flashing as specified in Section 07 62 00.
- E. Install joint sealants as specified in Section 07 92 00.

- F. Coordinate with electrical power as specified in Section 26 05 00.
- G. Install door limit switches and adjust for correct operation.
- H. Provide connection to piped services and utilities as specified in Section 22 10 00 and 23 21 00.

3.3 FIELD QUALITY CONTROL

- A. Adjust air curtains to function properly.
- B. Adjust air foil vanes located within the discharge nozzle as required for prevailing conditions at each opening.
- C. Check heated air curtain performance on a calm day by measuring air temperature 6 inches off the floor. Optimal reading is halfway between the temperature inside and outside the building.

3.4 CLEANING

- A. Clean air curtains promptly after installation in accordance with manufacturer's instructions.
- B. Repair minor damages to finish in accordance with manufacturer's instructions and as approved by Architect.
- C. Remove and replace damaged components that cannot be successfully repaired as determined by Architect.

3.5 PROTECTION

- A. Protect materials and finish from damage until substantial completion.

3.6 SCHEDULES

- A. Refer to Air Curtain Schedule appended to this section.

END OF SECTION



HV2 Submittal Package

atmosphere is everything

14716 S. BROADWAY, GARDENA, CA 90248 • Ph: (310)532-1555 Fax: (310)-532-3030 • www.marsair.com
© Copyright Mars Air Systems, LLC 2014

Reference Links

Link

Description

<https://marsair.com/>

Main website

<https://marsair.com/document-library>

**Submittals for all Mars Air Curtains,
Accessories, Installation, and Brochures**

<https://www.marsair.com/Content/Downloads/CSISpecs/HV2-NH2-CSI-Specification.doc>

HV2 Series CSI spec (Word doc)