

AZ9VH12DBM

GE Zoneline® Heat Pump Single Package Vertical Air Conditioner, 230-208 Volt

PERFORMANCE DATA AT 230 VOLT

- Nominal Cooling Capacity – 12,000 BTUh
- Cooling Capacity Range @95F – 5,000-16,000 BTUh
- EER – 11.8
- Heat Pump Capacity Range @47F – 5,000 - 16,000 BTUh
- COP @ 47F – 3.4
- Make Up Air SCFM Range – 37-90 (no filter) 18-70 (with MERV 13 filter)

DIMENSIONS AND INSTALLATION INFORMATION (IN INCHES)

MINIMUM CLEARANCES:

FRONT-ACCESS CLOSETS

- Allow 3" in front of unit, Allow 3" on each side of unit.

SIDE-ACCESS CLOSETS

- Allow 5" in front of unit, Allow 3" on each side of unit.

REQUIRED COMPONENTS FOR INSTALLATION

- Drain Platform (RAVDPLAT)
- Plenum
- Exterior Grille
- Return Air Grille/ Access Panel
- Remote Thermostat
- Power Connection Kit

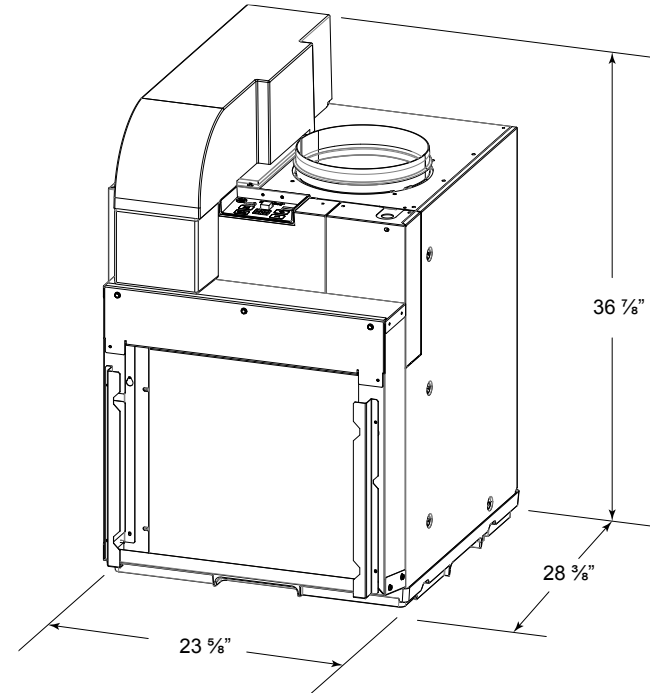

230-208V POWER CONNECTION REQUIREMENTS (RESISTANCE HEAT)

POWER CONNECTION KIT	RAK315D	RAK320D	RAK330D
Heater Watts	2450/2004	3450/2822	5000/4089
MCA	15	20	30
Recommend Protective Device (MOCP)	15 amp time-delay fuse or breaker	20 amp time-delay fuse or breaker	30 amp time-delay fuse or breaker



For answers to your Monogram, GE Cafe™, GE Profile™ or GE Appliances product questions, visit our website at geappliances.com or call GE Answer Center® Service, 800.626.2000.

AZ9VH12DBM

GE Zoneline® Heat Pump Single Package Vertical Air Conditioner, 230-208 Volt

FEATURES AND BENEFITS

Optimized, Efficient Operation – Our Inverter Driven, Variable Speed Compressor along with our proprietary algorithms provide cooling, dehumidification, and heat pump operation that adjusts to meet the needs of each unique installation - keeping comfort high and energy costs low!

Make Up Air Equipped – Dedicated variable speed fans allow for the delivery of site specific volumes of outdoor air (MERV 13 filtration is optional)

Ultra-Low Temperature Heat Pump Operation – Variable speed compressor and advanced defrost capabilities allow for efficient heat pump operation down to 0 degrees F.

Insta-Platform™ – One-piece design fully integrates with the wall plenum and aligns for a tight seal. Eliminates need for a customized platform construction on site

Self-Contained Drainage System – Easy installation and simple chassis removal while leaving plumbing completely intact

Fast-Connect Plumbing – Thoughtful design enables platform build and rough plumbing completed in only minutes

Quick-Install Plenum – Plenum is easily installed from the interior of building, without the need for exterior building access* (*caulking required)

Self-aligning, lock in place system – Perfect fit and mistake proof when the chassis is placed on the platform

Onboard Diagnostics – Electronic controls give clear and fast diagnostics data and fault codes, for quick and easy notifications

Anti-Corrosion Design – Exclusive rust-proof basepan and bulkhead provide another level of corrosion protection

Ultra-Quiet – Delivers quiet cooling power with a smooth sound for a good night's sleep

SmarterHQ WIFI capability – An optional WiFi module gives property managers the ability to oversee units, increasing productivity and enhancing guests' experience

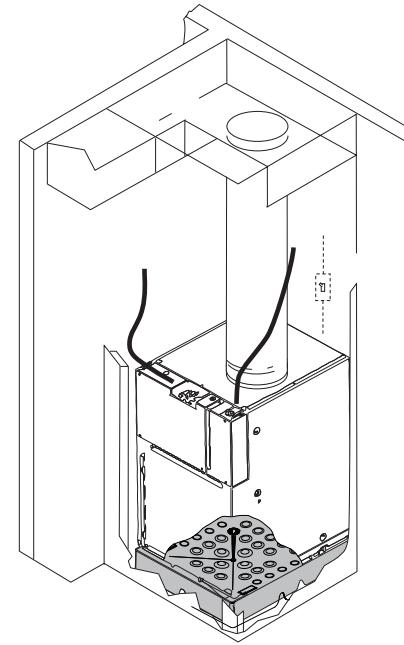

ZONELINE® WARRANTY*

WHAT IS COVERED

LIMITED ONE-YEAR WARRANTY

For one year from date of original purchase, we will provide, free of charge, parts and service labor on site to repair or replace any part of the Zoneline that fails because of a manufacturing defect.

LIMITED ADDITIONAL FOUR-YEAR WARRANTY

For an additional four years from the date of original purchase, we will provide, free of charge, parts and on-site service labor to repair or replace any part of the sealed refrigerating system (the compressor, condenser, evaporator and all connecting tubing) that fails because of a manufacturing defect.

*See Written Warranty For Detail

LIMITED 2ND THROUGH 5TH YEAR PARTS WARRANTY

For the second through the fifth year from date of original purchase, GE Appliances will provide, free of charge, parts that fail as a result of a manufacturing defect. Parts covered are fan motors, switches, heater, heater protectors, compressor overload, solenoids, circuit boards, auxiliary controls, thermistors, frost controls, capacitors and varistors. This is a limited parts-only warranty, and does not include labor or transportation to and from the service shop.

All warranty service will be provided by our Factory Service Centers or by our authorized Customer Care® servicers during normal working hours.

